



MATHIAS BÄUERLE

Mathias Bäuerle GmbH · Gewerbehallestraße 7-11

D-78112 St.Georgen · Telefon (07724) 882-0 · Telefax (07724) 882-111

Internet: <http://www.mbfold.de> · E-mail: center@mbfold.de

multimaster CAS 38

Version A



Operator's Manual

CONTENTS

1. GENERAL	5
2. SPECIFICATIONS	6
3. PROPER HANDLING OF THE MACHINE	7
4. SAFETY INSTRUCTIONS	9
5. SAFETY FEATURES	13
6. BASIC COMPONENTS OF THE MACHINE	14
7. SPACE REQUIREMENTS	15
8. OPERATING POSITIONS	15
9. ELECTRICAL CONNECTION	16
10. AIR FEEDER PBA 38	17
11. FLAT PILE FEEDER FSA 36	23
12. REGISTER TABLE	33
13. BUCKLE FOLD UNITS	35
14. ROLLER TABLE	37
15. DELIVERIES	39
Fanned Deliveries AM 52, AMS 52	39
Small Format Vertical Stacker SKM 36	40
16. AUTOMATIC SETTING	43
Operator Panel	43
Setting the Counter - Main Menu COUNTER	46
Clearing the Total Counter	46
Setting the Batch Counter	47
Set Kicker for Batch Counting	49
Paper Transport Control, Double Sheet Detection - Main Menu MONITORING	52
Paper Transport Control	52
Double Sheet Detection	53
Setting the Fold Length - Main Menu SET-UP	54
Standard Folds	54
Special Folds	61
Job Saved	72
Setting the Suction Length - Main Menu SET-UP	83
Saving of Job Data - Main Menu SAVING	86
Display of the Actual Job - Main Menu JOB	91
Correction of Fold Lengths - Menu FOLD LENGTH	92
Setting the Fold Rollers - Menu ROLLER GAP	93
Setting the Delivery Rollers - Menu DELIVERY	98
Choosing the Measuring System and the Language	100
Fold Plate Setting: Three Methods	101
Display of Malfunctions	104
Service Functions	105
17. OPERATION AND TRIAL FOLDS	109
18. FINE ADJUSTMENTS AND CORRECTIONS	111
19. PERFORATING-, SCORING- AND SLITTING TOOLS	115
20. POSSIBLE MALFUNCTIONS AND THEIR REMEDIES	121

The title, copyright and all other proprietary rights in this document are vested in Mathias Bäuerle GmbH and no part of it may be reproduced in any form without the written permission of Mathias Bäuerle GmbH.

1. GENERAL

General Description

The machines of the multimaster CAS 38 folder line are professional buckle folders with an infeed width of up to 38 cm. They can be equipped with one or two fold units. The fold units may be used in-line or at right angles. There is a choice between suction- and flat pile feeders.



The folders of the multimaster CAS 38 series can also be combined with other fold units from MB Bauerle. The conventional fold units multimaster 38 and MS 45 can also be used as third stations.

For these machine combinations, settings and operation are explained in the respective operator's manuals.

In addition to this operator's manual, the following separate manuals are available: multimaster 38, knife fold unit MS 45.

Folding Principle

The infeed rollers (1) and (2) transport the sheet to be folded into the fold plate (3).

As soon as it comes up against the adjustable stop (4), the sheet forms a buckle (5) because the infeed rollers keep on moving.

The loop gets bigger until the sheet is seized by rollers (2) and (6); this is where the actual fold occurs.

The rollers draw the folded sheet from the fold plate and the infeed rollers and move it on.

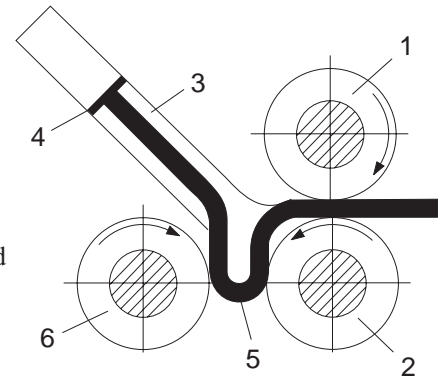

2. SPECIFICATIONS

Paper size:	Maximum	Minimum
	W x L	W x L
Air feeder PBA 38:	38 x 65 cm	7* x 12 cm
	*(less if paper is guided on one side only)	
Flat pile feeder FSA 38:	38 x 65 cm	10 x 12 cm
Fold length min.:	3.5 cm	
	1.8 cm with fold unit for small formats	
Speed:	200 m/min	
Paper weight:	40 - 250 GSM for single fold	
Electrical:	Voltage: 3 x 400V / 50 Hz / N / PE or 3 x 208V / 60 Hz / PE	
	Current consumption: max. 10A	
	Power consumption:	
	- 1st fold unit with feeder:	0.9 kW
	- 2nd fold unit with roller table:	0.9 kW
	- Delivery:	0.1 kW
	- Pump:	2 x 1.1 kW
Ambient conditions:	Room temperature:	15 - 40°C
	Air humidity:	50 - 90%
Weight (net):	1st fold unit with PBA 38, register table	270 kg
	2nd fold unit, roller table	230 kg
	Delivery A 38	25 kg
	Delivery AM 52	60 kg
	Small format vertical stacker SKM 36	60 kg
	Pump	2 x 17 kg
Noise emission:	Sound power level of the emission values measured at specific sections of the machine (machines with flat pile feeder):	
	- Feeder section:	83 dB (AI)
	- Delivery section:	85 dB (AI)
	Measured according to DIN 45 635, part 27	

3. PROPER HANDLING OF THE MACHINE

The machines of the multimaster CAS 38 folder line are built for folding paper. They may also be used for perforating, scoring, slitting, cutting and counting paper using the proper attachments.

They are unsuitable for handling other materials such as foil, plastics and textiles. The manufacturer / distributor is not responsible for damages resulting from such unsuitable applications. Responsibility lies alone with the user.

Reading the Operator's Manual and observing the conditions for inspection and maintenance are part of the proper handling of the machine.

Installation of the machine, i.e. assembling as well as electrical and pneumatic work should be carried out only by skilled personnel authorized by the manufacturer or his representatives. Additional instructions are provided for this purpose.

Repairs and service should be carried out only by skilled personnel authorized by the manufacturer or his representatives.

The interval between inspections including safety-related functions depend on the machine usage.

For regular one-shift-operation, one inspection per year is recommended.

The machine needs a flat surface for installation.

The machine weight should be considered when choosing a location for the machine.

The levelling screws in the undercarriage of the machine can compensate for an uneven floor to a certain degree.

To ensure stability during operation the machine should be secured by means of the levelling screws.

The line voltage must correspond to the voltages on the serial plate.

No harmful emissions are produced.

Read the Operator's Manual before working with the machine.

We recommend to carry out all operations and settings in the sequence mentioned in this manual.



The terms "right" and "left" in the following text always refer to the direction of paper travel. Therefore the left side is the operator side.

4. SAFETY INSTRUCTIONS

4.1 Safety Instructions for Transport and Set-Up

The following instructions and warnings are applied to the packing to ensure appropriate and safe transport:

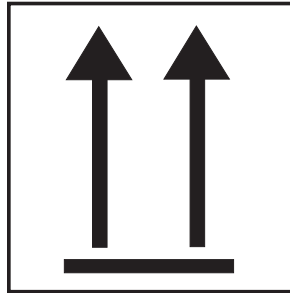

Top! - Transport in upright position only!



Protect from humidity!



Fragile! - Handle with care!

These instructions and warnings must also be observed for transport within the users premises.

For transport to other premises resp. for return shipment the machines must be packed and provided with the same markings.

4.2 Fundamental Safety Instructions

Warnings and Symbols

The following symbols and designations are used in the manual to identify instructions of particular importance:



General instructions and special information how to use the machine most efficiently.



Instructions designed to prevent injury or extensive equipment damage.

Basic Operation

The machine has been built in accordance with state-of-the art standards and the recognized safety rules.

Nevertheless, operators and third parties may get injured when working with the machine, or damage to the machine and to other material property may result. The machine must only be used in technically perfect condition in accordance with its designated use and the instructions set out in the operator's manual. Any malfunctions, especially those affecting the safety of the machine, should therefore be rectified immediately.

Organizational Measures

The operator's manual must always be available near the machine. In addition to reading the operator's manual, observe and instruct the user in all other generally applicable legal and other mandatory regulations relevant to accident prevention and environmental protection.

The operator's manual must be supplemented by instructions covering the duties involved in supervising and notifying special organizational features, such as job organization, working sequences or the personnel entrusted with the work.

Personnel entrusted with work on the machine must have read the operator's manual and in particular the chapter on safety before beginning the work.

Reading the instructions after work has begun is too late.

This applies especially to persons working occasionally on the machine, e.g. during setting up or maintenance.

Check, at least from time to time, whether the personnel is carrying out the work in compliance with the operator's manual and paying attention to risks and safety factors. For reasons of safety, long hair must be tied back or otherwise secured, garments must be close-fitting and no jewellery - such as rings - may be worn.

Injury may result from being caught on moving parts.

Observe all safety instructions and warnings attached to the machine.

See to it that safety instructions and warnings attached to the machine are always complete and perfectly legible.

In the event of safety-relevant modifications or changes in the performance of the machine during operation, stop the machine immediately and report the malfunction to the competent person.

Never make any modifications, additions or conversions which might affect safety without the manufacturer's approval. Adhere to prescribed intervals or those specified in the operator's manual for routine checks and inspections.

Selection of Personnel, Basic Responsibilities

Employ only trained or instructed staff and set out clearly the individual responsibilities of the personnel for operation, set-up, maintenance and repair.

Work on the electrical system and equipment of the machine must be carried out only by a skilled electrician in accordance with electrical engineering rules and regulations.

Standard Operation

Avoid any operational mode that might be detrimental to safety. Take the necessary precautions to ensure that the machine is used only in a safe and reliable state.

Operate the machine only if all protective and safety-oriented devices, such as removable safety devices, emergency stops, sound proofing elements, are in place and fully functional. In the event of malfunctions stop the machine immediately and prevent further use. Have any defects rectified immediately.

Before starting up or setting the machine in motion, make sure that nobody is in danger.

Special Work, Maintenance, Repair

Observe the adjusting, maintenance and inspection activities and intervals set out in the operator's manual, including information on the replacement of parts and equipment.

Pull the power plug for maintenance and repair work or before opening the control box.

If the machine is completely shut down for maintenance and repair work, it must be secured against inadvertent starting by attaching a warning sign to the main switch. Always tighten any screw connections that have been loosened during maintenance and repair.

Special Dangers

The electric equipment of machines is to be inspected and checked at regular intervals. Defects such as loose connections or scorched cables must be rectified immediately.

Product-Specific Safety Instructions



**Exercise caution in the vicinity of rotating shafts and rollers!
Hair, loose garments and jewellery may get caught!
SERIOUS INJURY MAY RESULT!**



**Exercise caution in the vicinity of the perforating- and slitting knives!
They have sharp edges for proper function!
SERIOUS INJURY MAY RESULT!**

4.3 Cleaning and Maintenance

Regular and proper cleaning contributes to a long life of the machine and a consistent quality. Therefore it is important to clean the machine in regular intervals and above all to remove paper dust.

The interval between maintenance jobs depends on the workload.
It is recommended to clean the machine once a week.



Before cleaning the machine always pull the power plug!



**Exercise caution in the vicinity of the perforating- and slitting knives!
They have sharp edges for proper function!
SERIOUS INJURY MAY RESULT!**

Use only the special cleaning fluid from MB for cleaning the fold rollers.

Do not use any solvents such as Acetone or Toluol. They would damage the non-metal parts of the rollers.

Remove paper- or print powder dust from all fixed and moveable parts of the machine.

Clean the photodetector with a brush.

Use compressed air to clean the fold plates when paper with a high degree of powder has been folded. Carefully remove deposits in the control box with a vacuum cleaner.

Clean the air filter of the compressor and the pump using brushes or air.

The maintenance-free flat belt drive needs no lubrication of any kind.

5. SAFETY FEATURES

The machines of the multimaster CAS 38 folder line are equipped with various safety features. They ensure the safety of the persons working with the machine.

The following safety features are found on these machines:

- 1 Fixed cover at the fold roller infeed section
- 2 Swing-up noise covers
- 3 Safety handwheels
- 4 Emergency stop buttons

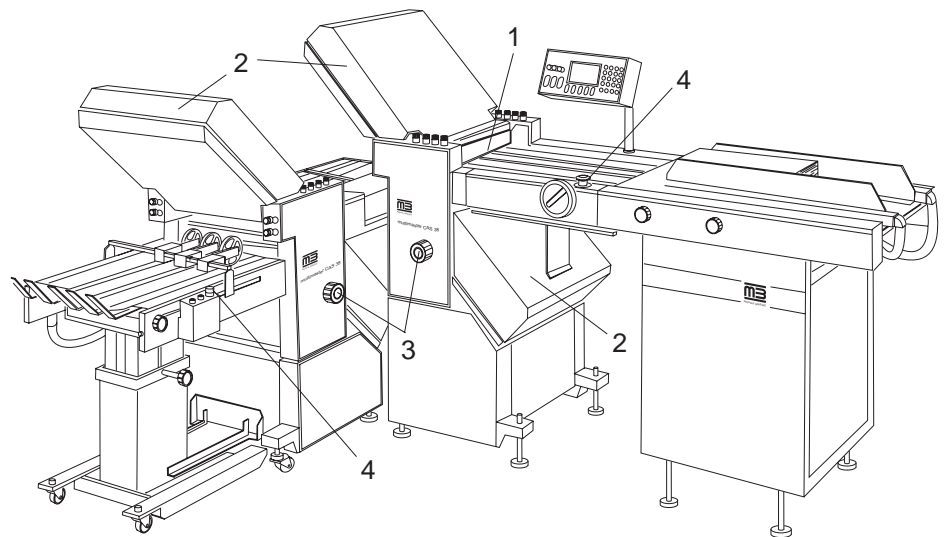

Possible remaining risks are pointed out in the respective paragraphs of this manual.

6. BASIC COMPONENTS OF THE MACHINE

As a result of its modular design, the multimaster CAS 38 offers a wide range of applications and configurations to suit the requirements of the user.

The following components are available:

- Flat pile feeder FSA 38
- Bottom feed, top loading air feeder PBA 38
- 1st buckle fold unit (automatic setting) with register table (CAS 38)
- 2nd buckle fold unit (automatic setting) with roller table (CAS 38)
- 3rd buckle fold unit (manual setting) with roller table (38) - separate operator's manual
- Mobile knife fold unit MS 45 (manual setting) - separate operator's manual
- Fold unit for small formats KF 31 (manual setting)
- Fanned delivery AM 52
- Fanned delivery AMS 52
- Small format vertical stacker SKM 36

The model designations of the machines give an idea about the technical specifications at a glance.

Examples:

multimaster CAS 38/4, PBA

38	Infeed width 38 cm
4	1st buckle fold unit with 4 fold plates
PBA	Suction feeder PBA 38

multimaster CAS 38/4/2, PBA

38	Infeed width 38 cm
4	1st buckle fold unit with 4 fold plates
2	2nd buckle fold unit with 2 fold plates
PBA	Suction feeder PBA 38

multimaster CAS 38/4/4, FSA

38	Infeed width 38 cm
4	1st buckle fold unit with 4 fold plates
4	2nd buckle fold unit with 4 fold plates
FSA	Flat pile feeder FSA 38

7. SPACE REQUIREMENTS



When choosing a location for the machine, please bear in mind that additional space for the operator, for service and for pallets is needed in the feed- and delivery areas.

multimaster CAS 38/4, PBA

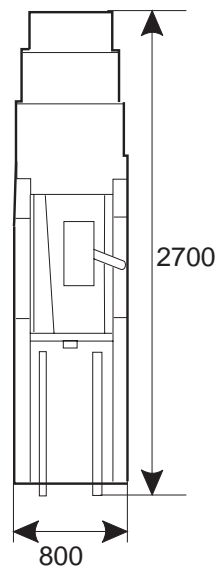

multimaster CAS 38/4/2, PBA

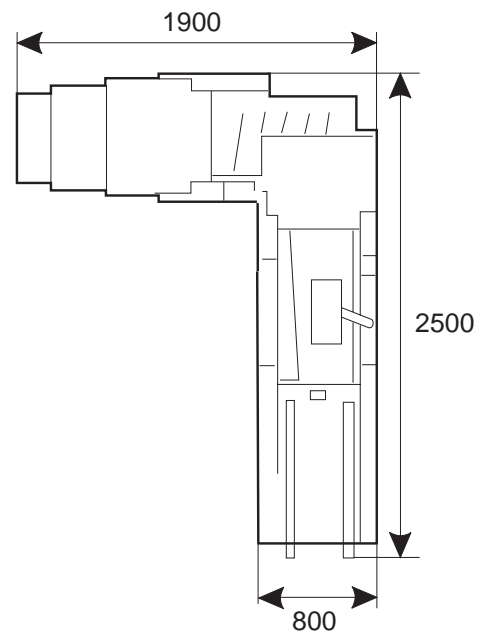

8. OPERATING POSITIONS

There is no fixed operator position at the machines. The operator must move between the following positions:

- 1 Feeder section for loading the unfolded paper
- 2 Operator panel for set-up
- 3 Delivery section for removing the folded paper

In addition, the machines should be accessible from any other position for cleaning, resetting, jam clearance, service jobs, etc.

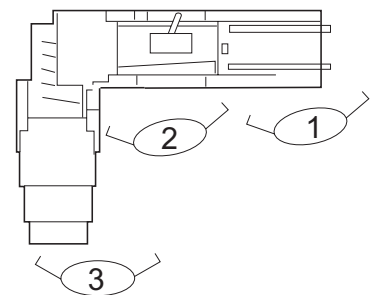

9. ELECTRICAL CONNECTION

Operator panel, fold units and delivery are interconnected with cables. Plugs and sockets allow variable connections.



Do not bend or twist the cables sharply or place heavy objects on them - they may get damaged!



When making or breaking any electrical connection, always first turn off the main switch or the safety switch on the folder. Non-compliance may cause damage to electronic components!

At the rear of the base of each fold unit you will find the sockets for connecting the various fold units and accessories.

Buckle fold unit 1

- 1 Socket for the connection cable to the operator panel
- 2 Receptacle 230V for accessories
- 3 Socket for the connection cable of the second fold unit or the delivery
- 4 Safety switch
- 5 Connection cable of the pump
- 6 Connection cable of the pump
- 7 Power cord 400V

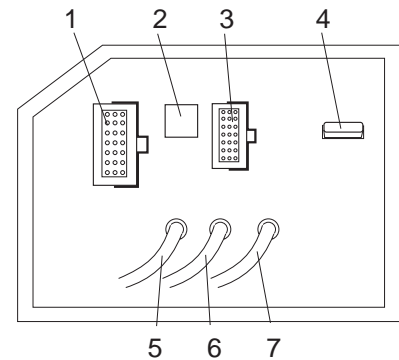

Buckle fold unit 2

- 8 Connection cable for connection to the socket at the first fold unit
- 9 Socket for the connection cable of the delivery

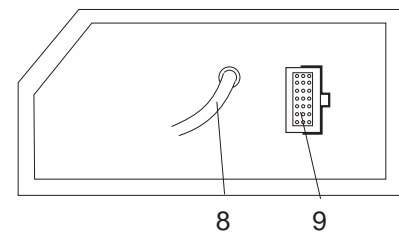

Plug connections are easily pulled or inserted by holding the plug with one hand and opening resp. closing the safety bracket with the other hand.

10. AIR FEEDER PBA 38

Principle of Operation

The air feeder PBA 38 consists of a feeder and a register table.

It is suitable for handling a wide variety of papers - uncoated papers as well as coated, freshly printed or thin papers.

The sheets are separated by air and vacuum.

Air is supplied from the bottom of the stack both on the left and right side, separating the paper in the stack which now floats in a cushion of air.

A rotating suction drum can then separate the sheets from the bottom of the paper stack.

This principle has the advantage that paper can be continuously reloaded with the machine running. There is no need to stop the machine.

On the register table, a transport belt, which runs at an angle, moves the sheets against a register rail.

Description

Components and operating elements of the air feeder PBA 38:

- 1 Feed table
- 2 Air guides left and right
- 3 Knobs for adjusting the air guides
- 4 Rear paper stop
- 5 Air adjustment valves
- 6 Suction drum with suction segment
- 7 Front paper stop
- 8 Guide rollers
- 9 Lever for adjusting the suction segment
- 10 Lock screw
- 11 Window for adjustment of suction segment
- 12 Vacuum adjustment valve
- 13 Register table
- 14 Ball cage
- 15 Handwheel
- 16 Lock screw
- 17 Lever for adjustment of sheet gap
- 18 Hold-down bars
- 19 Alignment rail
- 20 Adjustment wheel for changing the infeed angle

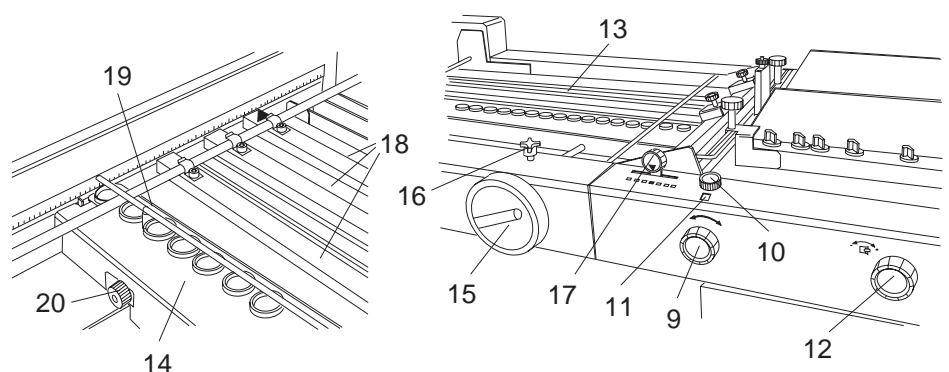
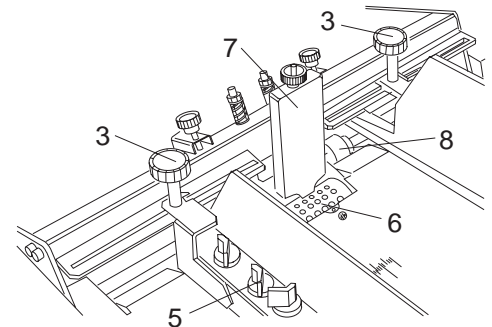
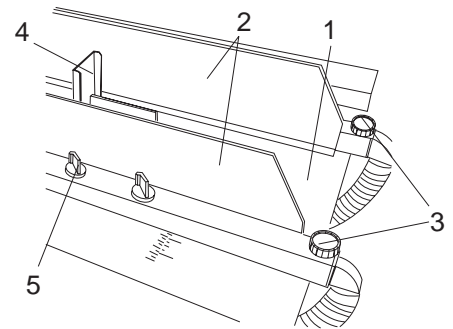

Setting the Format

 When setting the format, care should be taken that the sheets are fed approximately from the center.

- Loosen the handles (1) by turning them counter-clockwise.
- Set the left feed guide to half sheet width with the help of the scales (2).
- Tighten the handles (1) again.
- Place a stack of about 50 sheets on the feed table.
- Slide the right feed guide (3) against the edge of the stack.

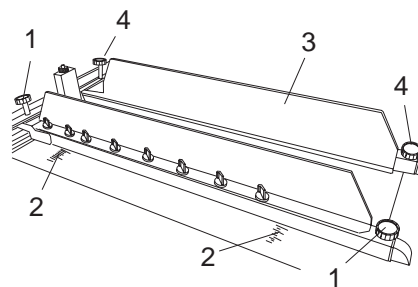

 Make sure that the sheet does not actually touch the guide. There should be a gap of approx. 0.5 mm. The right and left feed guide should be parallel.

- Tighten the handles (4) at the right feed guide.

 If the width of the paper is less than 7 cm, only one paper guide can be used.

Setting the Sheet Separation

Sheet separation is achieved by the combined action of the rotating suction drum, the paper stop and the air.
Paper weight and type of paper have an influence on the setting.

Setting the Air

A suction drum (5) separates the sheets from the bottom of the stack.

This is achieved by the suction segment (6) inside the suction drum.

The angle of the suction segment with respect to the paper stop can be changed to suit different types of paper.

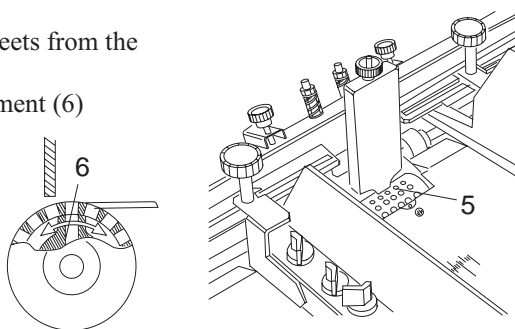

Basic setting

- Loosen the lock screw (7).
- Turn the knob (8) until the figure "6" on a red background appears in the window (9).
- Tighten the lock screw (7).

Now the suction segment is in its zero position (10).

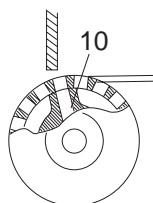
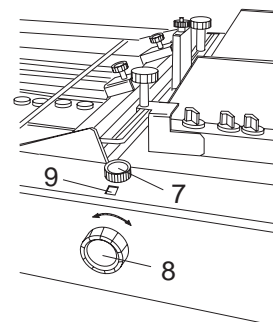

Most types of paper with a weight of 80 to 90 GSM can be separated in this position.
For different paper grades, other figures must be set in the window:

- Paper grades below 80 GSM: 7 - 9
- Paper grades above 90 GSM: 1 - 5

Setting for light paper grades:



For running light-weight paper, first try the suction segment setting as described under "Basic Setting".

A steeper inclination is only necessary for special types of paper.

Light paper grades easily cling to the curve of the suction drum.
Therefore the suction segment must be tilted in direction of the paper stop.

The inclination of the suction segment in this direction has the effect that the paper is wrapped around the suction drum (1).

The sheets are easily separated from the stack and double sheets occur very rarely.

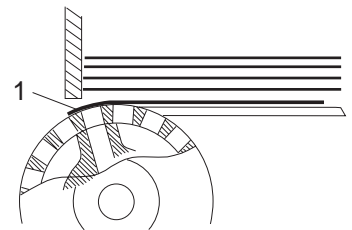

In the batch counting mode it may happen occasionally that a single sheet is fed during the interval time.

This is caused by the fact that the suction drum continues to turn during the interval time (although without vacuum). For light paper grades the friction between paper and suction drum may be sufficient for detaching a sheet.

To prevent this, a special plate (2) can be placed over the suction drum. This plate, which is pulled out of the feed table, can cover the suction drum to its highest point (3).

Sheets are no longer affected by the friction of the suction drum.

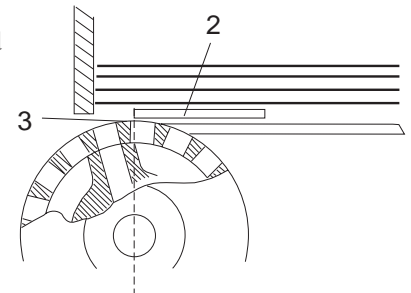

Proceed as follows to pull out the plate:

- Loosen the screw (4).
- Insert a screwdriver in the hole (5).
- Pull out the plate.
- Tighten the screw (4).

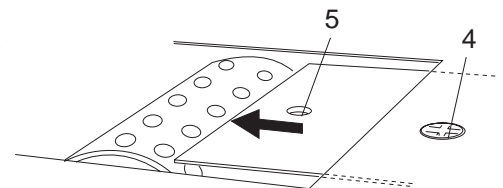

Setting for heavy paper grades

Heavy paper grades do not easily cling to the curve of the suction drum.

For this reason the suction segment must be tilted in direction of the paper stack.

The inclination of the suction segment in this direction has the effect that the paper is barely wrapped around the suction drum (1).

This is sufficient because heavier paper grades are more easily separated from the stack.

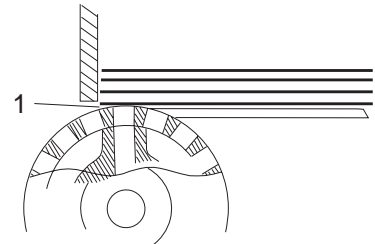
**Vacuum:**

Vacuum can be modified by means of a regulating valve (2). This is necessary because heavy paper grades require more vacuum than light paper grades.

The vacuum can be modified by turning knob (2).

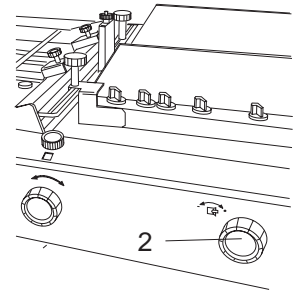
**Setting the vacuum:**

For setting the vacuum, the machine must be turned on.



**Exercise caution in the vicinity of rotating shafts and rollers!
Hair, loose garments and jewellery may get caught!
SERIOUS INJURY MAY RESULT!**



**Do not get close to rotating shafts and rollers while the machine is running and the noise-absorbing cover is open!
SERIOUS INJURY MAY RESULT!**



**Exercise caution in the vicinity of the perforating- and slitting knives!
They have sharp edges for proper function!
SERIOUS INJURY MAY RESULT!**

- Close the valve (2) for setting the minimum effect.
- Start the machine.
- Slowly open the valve (2) by turning the knob clockwise. Observe the sheet separation while doing this.



At first no sheets are pulled off the stack or they are pulled off irregularly. The more the valve is opened, the smoother is the paper transport.



Make sure that much vacuum does not cause feeding of double sheets.

- Switch off the machine.

Air

- Open the valves (1) at both air brackets.

 In most cases it is sufficient to open the second and the last valve (with respect to the format length).

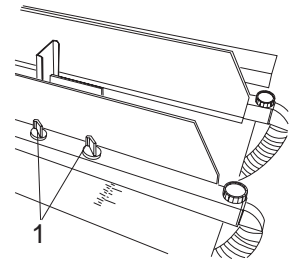
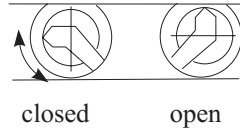



Front Paper Stop

The position of the front paper stop (2) can be adjusted in a horizontal and vertical direction.

Adjusting the horizontal position:

The horizontal position of the front paper stop determines the suction point on the paper and in turn depends on the position of the suction segment in the suction drum.

 The inclination of the suction segment must be set correctly before making the horizontal adjustment.

 When the suction segment is adjusted, the horizontal position must also be changed accordingly.

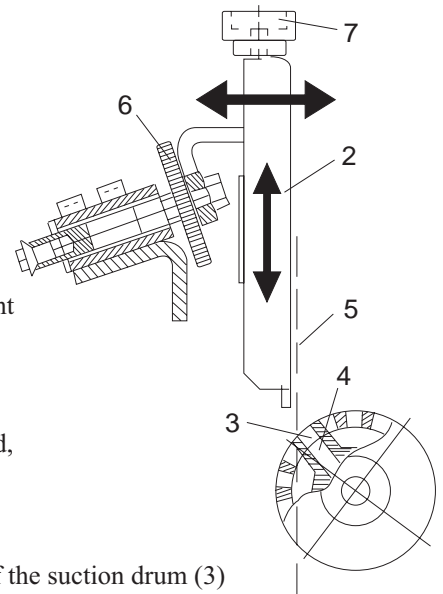

- Turn the handwheel until the openings of the suction drum (3) are exactly above the openings of the suction segment (4).
- Adjust the horizontal position of the front paper stop in such a way that it forms a vertical line (5) with the leading edge of the suction openings. To achieve this, turn the knurled screw (6) counter-clockwise or clockwise.

Adjusting the vertical position:

The respective paper thickness is set by adjusting the vertical position of the front paper stop. Proceed as follows:

- Place a stack of about 50 sheets on the feed table.
- Start the machine.



Exercise caution in the vicinity of rotating shafts and rollers!
Hair, loose garments and jewellery may get caught!
SERIOUS INJURY MAY RESULT!



Do not get close to rotating shafts and rollers while the machine is running and the noise-absorbing cover is open!
SERIOUS INJURY MAY RESULT!



Exercise caution in the vicinity of the perforating- and slitting knives!
They have sharp edges for proper function!
SERIOUS INJURY MAY RESULT!

- By turning the knurled screw (7), adjust the vertical position of the paper stop in such a way that only one sheet is pulled off the stack.

Positioning the Paper Stack

- Fan the paper stack well to avoid double sheets.
- Place the stack on the feed table.
- Position the rear paper stop. It prevents the paper from sliding off the table.

Sheet Gap

For normal folds the sheet gap should be set only via the potentiometer (1) on the operator panel.

However, if small formats with a length below 20 cm are to be folded, the sheet gap can also be adjusted by means of a lever (2).

The adjustment changes the speed of the suction drum, i.e. different speeds of feeder and fold rollers result in different sheet gaps.

A smaller sheet gap increases the speed of the folder, independent of the cycle frequency.

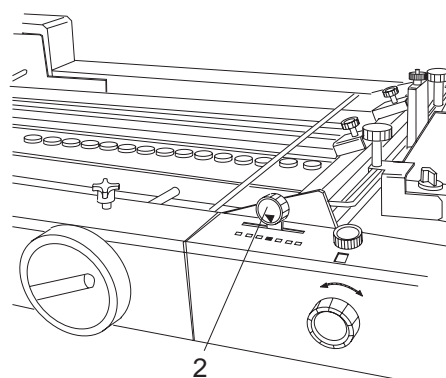
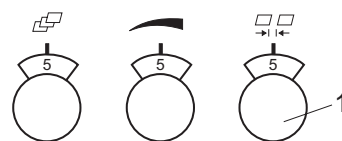

Lever in right position:

Adjustment of small formats below a length of 20 cm.

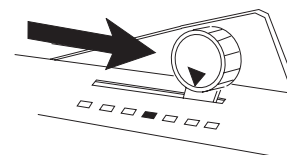

Lever in center position:

Setting for all "normal" folds.

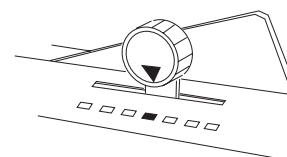

The adjustment can be made with the machine running.



To increase the sheet gap, always use the potentiometer (1) on the operator panel, do not use the lever.

11. FLAT PILE FEEDER FSA 38

Principle of Operation

The flat pile feeder FSA 38 with rear edge separator is suitable for separating different kinds of paper, uncoated as well as coated, freshly printed or thin paper.

Sheet separation is done by vacuum and air from the top of the paper stack. Air blowers separate the top sheets at the rear edge of the stack.

Sheet separators lift the uppermost sheet by approx. 2 cm.

This opens the rear air nozzles and an uninterrupted stream of air is blown under the separated sheet.

The suction drum at the front edge of the stack grips the sheet and leads it onto the register table.

Description

Components and operating elements of the flat pile feeder FSA 38:

- 1 Pile table
- 2 Stacking stops
- 3 Carrier arm for rear edge separator
- 4 Rear edge separator
- 5 Operator panel
- 6 Valves for regulating the air flow
- 7 Sheet separator height adjustment
- 8 Knurled knob for rear edge separator
- 9 Knurled knob for stripper springs
- 10 Rear separator nozzles
- 11 Front separator nozzles
- 12 Hold-down rods
- 13 2 sucker cups
- 14 Suction drum with suction segment
- 15 Lever for adjustment of suction segment
- 16 Rear edge separator lock lever

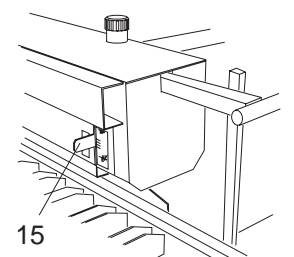
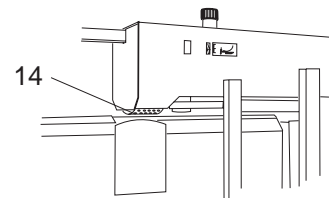
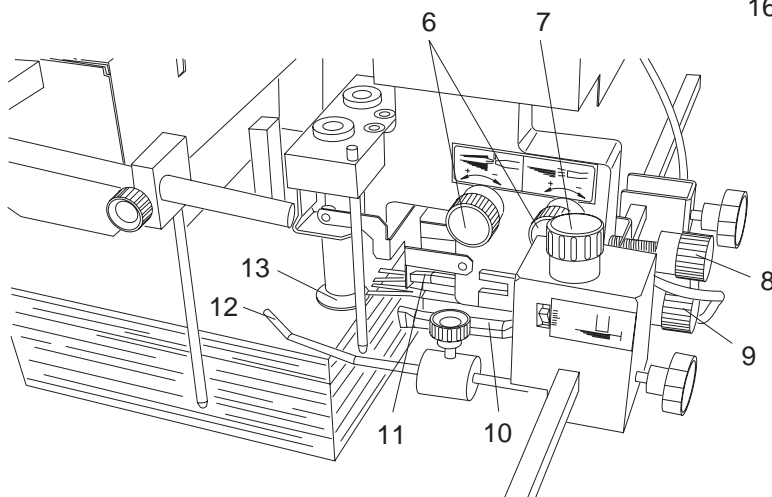
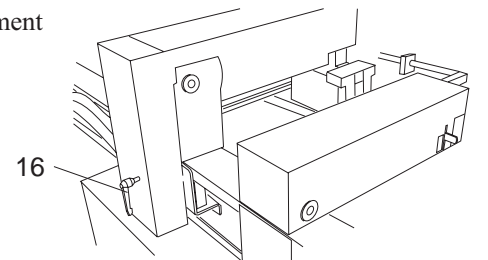
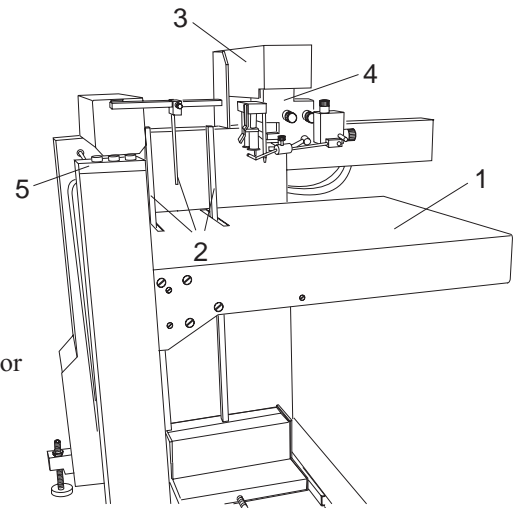

Setting the Format

- Tilt up the front stop (1).
- Push down the rear stop (2) and slide it to half the sheet width with the help of the scale (3).

 The second rear stop (4) can be pulled out. This is necessary, if, for instance, the rear edge separator is in this position when feeding smaller paper sizes.

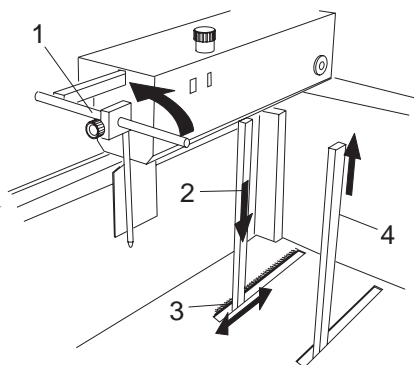

Loading the Pile Table

- Turn on the main switch at the folder.
- Lower the pile table.

The operator panel of the flat pile feeder has three push-buttons for lowering and raising the pile table.

Button (5): Pile table up:
The pile table moves up automatically to the correct position.

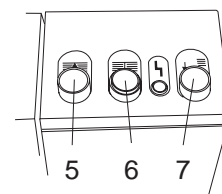

Button (6): Pile table down:
The pile table moves down, but only as long as the push-button is pressed.

Button (7): Auto mode:
The feeder is designed in such a way that the pile table moves down automatically for reloading. This ensures that the loading height is always in an ergonomically favorable position. The distance that the pile table moves down corresponds to the height of the paper stack that is being replenished. The height adjustment is controlled by a photodetector (8). The photodetector can be adjusted by loosening a knob (9), thus making it possible to adapt the stack height to suit the operator.

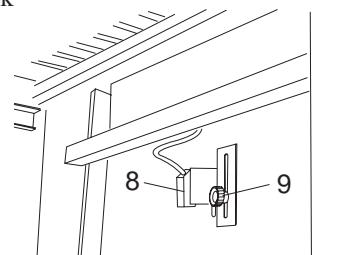

- Tilt up the rear edge separator (10).
- Load paper on the pile table.

 Use the automatic stacking mechanism. Push button (7) after each reloading process. This will lower the table automatically.

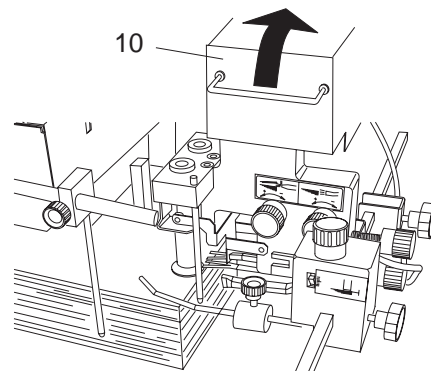

Moving the Paper Stack to Work Position

When the pile table is loaded, the paper stack must be brought to the work position.

- Push button (1).
The stack moves automatically to the correct position, controlled by the stack sensor switch (2).

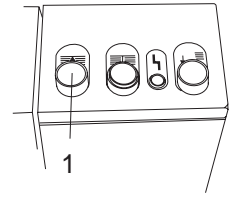

- The stack height switch is a capacitive sensor that reacts to the density of the paper stack. For this reason the gap between stack and suction drum can vary when the paper stack has reached the work position depending on the type of paper used.

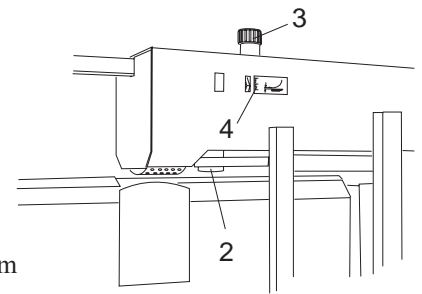

- The gap between stack and suction drum should be 8 mm.

- Set the gap to 8 mm by turning the setting screw (3).
A scale (4) facilitates this setting.
- Lower the front stop (5) and slide it against the paper stack.

- This tiltable stop can also be replaced by a stop rod (6).
The stop rod is attached to the pile table with a lock screw (7).
The tiltable stop (5) must then be moved up so that it does not interfere with the stop rod.

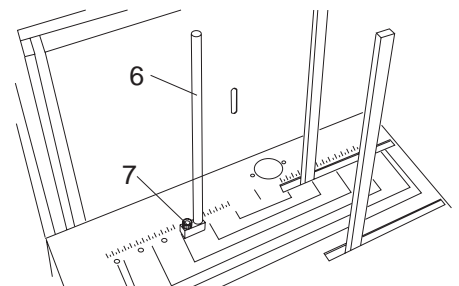
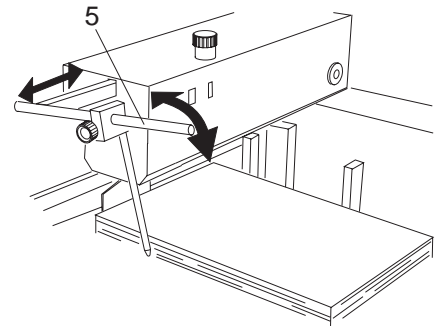

Air and Vacuum

Turn on the pump at the operator panel before setting air and vacuum.
The correct setting for air and vacuum can only be determined by running a few sample sheets after all adjustments have been completed.

Exchanging the Suction Drum

The suction drum (1) is equipped with two PUR-rings for reliable sheet detachment. If marks occur on sensitive or freshly printed paper, a different suction drum (accessory) can be used. This suction drum has a PUR-coating over the entire surface and consequently a higher coefficient of friction.

For installation of this suction drum proceed as follows:

- Pull off the cover (2).
- Loosen the screw (3) and remove the suction drum.
- Install the PUR suction drum.
- Tighten the screw (3).
- Replace the cover (2).

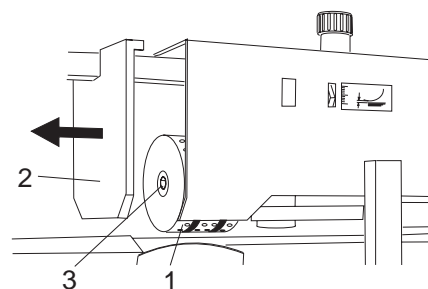

Adjusting the Suction Segment

The suction drum (4) separates the leading edge of the sheets from the stack. For this purpose there is a suction segment inside the suction drum. The suction angle can be changed by adjusting the lever (5) to adapt suction point and suction area to different types of paper. A scale (6) facilitates the adjustment.

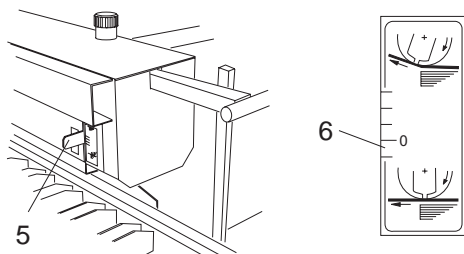
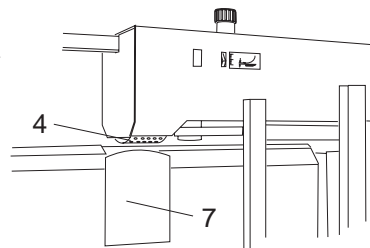

 In most cases an adjustment is only necessary for light paper stock resp. paper with a downward curl.

 Fine adjustment is only possible with the machine running.

 In connection with the adjustment of the suction segment, the height of the separator plate (7) can also be varied.

Setting the Rear Edge Separator

- Lower the rear edge separator (1).
- Loosen the lock lever (2).

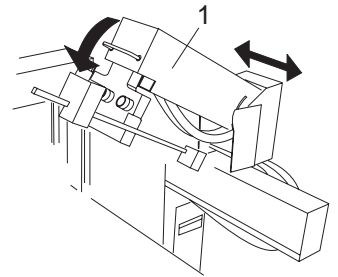
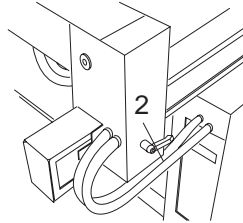

- Displace the rear edge separator in such a way that the stop rods (3) touch the rear edge of the paper stack.

 The edges of the sucker cups (4) should be placed approx. 3-4 mm from the rear edge of the paper stack.

 For light paper stock it is recommended to place the suckers even closer to the rear edge of the stack. This is achieved by moving the stop rods (3) to the next set of holes (5).

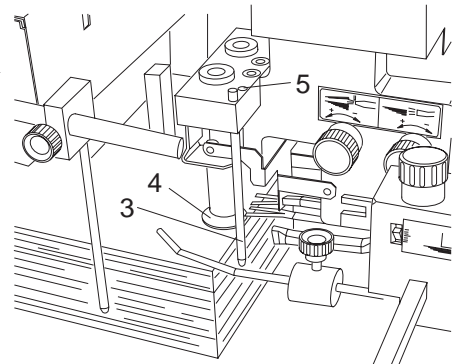

- Tighten the separating head by turning the lock lever (2) clockwise.

- Slide the left and right hold-down rods (6) towards the outer edge of the paper stack (approx. 1 cm inside the edge).

- Adjusting the pressure of the hold-down rods:
Heavy paper grades: Slide the weight (7) up.
Light paper grades: Slide the weight down.

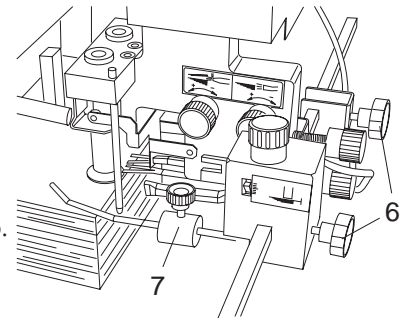

- Check whether the automatic height setting mechanism is switched on.

 The automatic height setting mechanism can be switched on and off by pushing button (8). The illuminated button shows that it is active.

 For smaller paper sizes or flat sheets the automatic height adjustment is often not needed and can therefore be switched off.

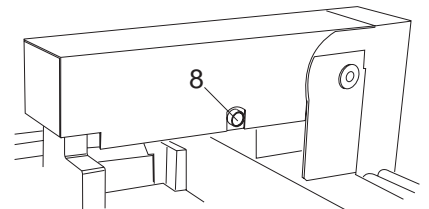

- Adjust the automatic height setting as follows:

The left hold-down bracket (1) also serves as a height sensor controlling the height adjustment of the rear edge separator. As a result, the gap between the suckers and paper stack remains always the same although sheets are pulled off continuously. The basic position can be changed by means of a knob (2). A scale (3) facilitates the adjustment.

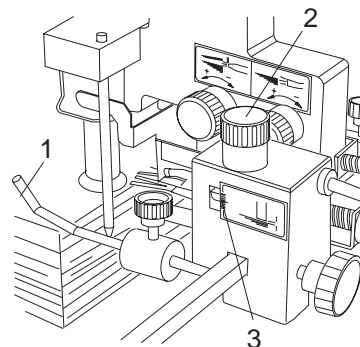

Increasing the gap: Move indicator to the plus-range "+".
 Reducing the gap: Move indicator to the minus-range "-".

Basic setting: Sucker cups should be 1-2 mm above the paper stack (with air turned off).

Adjusting the Stripper Springs

The stripper springs (4) should reach about 2 mm into the stack to prevent double sheets. The position of the springs can be adjusted by means of a thumb screw (5).

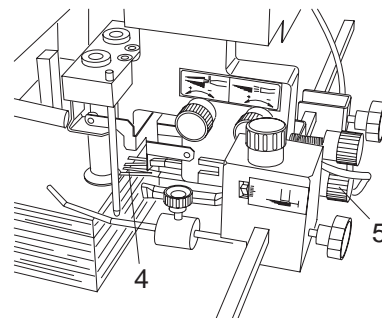

- Turn the thumb screw counter-clockwise: Springs move away from the stack.
- Turn the thumb screw clockwise: Springs move into the stack.

 If double sheets occur, the stripper fingers must be adjusted in such a way that they reach further into the stack.

Making the Sucker Cups Inoperative

 For short formats it is often advantageous to work without rear edge separators. In this case the sucker cups can be made inoperative.

- Move the sucker cups to the top position (6).
- Push the lock lever (7) backwards. This will lock the sucker cups in the top position.
- Switch off the automatic height setting mechanism.

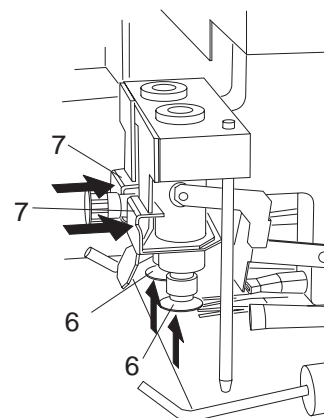



Now the air continuously separates the sheets from the rear edge.

Air

The air separates the rear edge of the paper stack by means of two rear separator nozzles (1). The volume of the air can be adjusted by means of a valve (2). The effect of the air can be influenced by changing the angle of the rear separator nozzles. They can be pointed up- or downwards by turning a thumb screw (3).

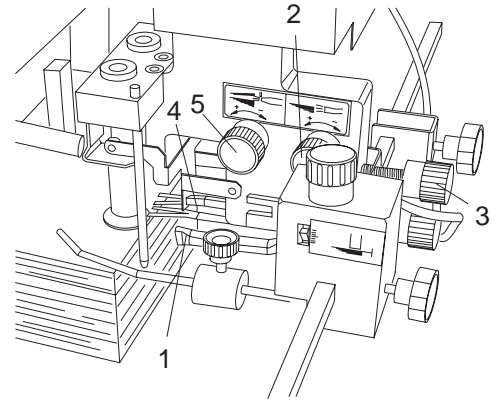
- Air directed upwards:
Turn the screw counter-clockwise.
Too high: Double sheets may occur.
- Air directed downwards:
Turn the screw clockwise.
Too low: Sheets on top are not fanned properly.



 Air volume and angle are set correctly when the top 10 - 15 sheets separate easily.

 Use as little air as possible for proper function.

Another separator nozzle (4) is positioned between the rear separator nozzles. It creates an air cushion under the separated sheet so that it attaches itself to the suction drum. The air volume can be adjusted by means of the valve (5).

 Most setting elements are equipped with scales. For repetitive feeding jobs it is recommended to mark the settings at the scales. The machine can thus be set-up more quickly. Please note that the same result can only be reached if all conditions are the same.

To support the air cushion, front blowers (6) can be used. They blow air under the leading edge of the sheets so that the sheets cling more easily to the suction drum.

The air volume can be controlled by means of a valve (7), which can be closed completely by turning it clockwise.

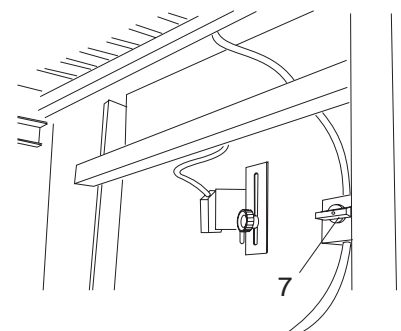
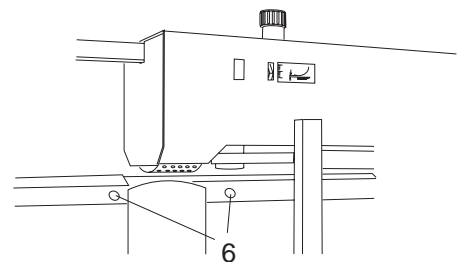

Additional Blower

An additional single blower (1) (optional) stabilizes the air cushion near the leading edge of the floating sheet. This is especially useful for long and narrow sheets.

The single blower (1) is positioned next to the front stop (2), while the stop plate (3) which comes with each single blower is pushed onto the rear paper stops.

When the single blower is used, the front blowers must be made inoperative. For this purpose detach the hose (4) for the front blowers from the valve (5) and connect the air hose (6) of the individual blower in its place.

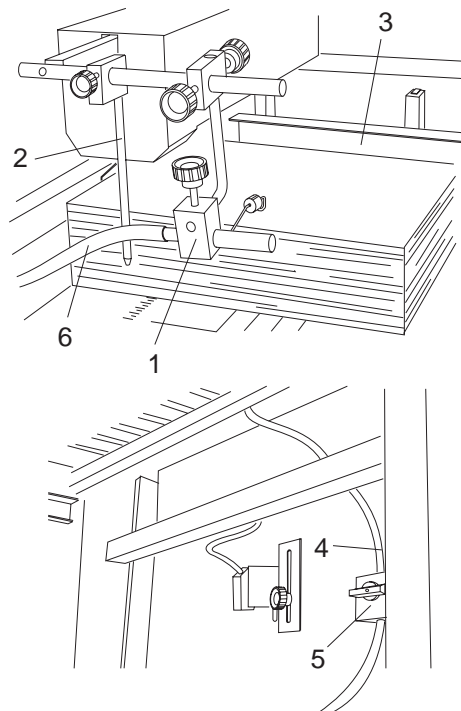

Side Blowers

The feeder can also be equipped with side blowers in the place of the rear edge separator (see separate mounting instructions). By supplying air to the side and rear edge of the stack, the topmost sheets are detached so that separation through the suction drum is possible. Contrary to operation with the rear edge separator, the topmost sheet is not lifted.

The air nozzles (7) are attached to cross-bars at the side (8) and the rear (9) of the paper stack. For replenishing paper, the two cross-bars can be raised to provide access to the pile table.

After the replenishing process the bars are returned to the working position.

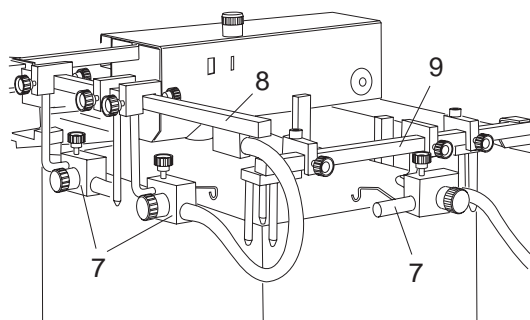

Format setting:

- Move the rear cross-bar (1) (secured with a clamp lever) in such a way that the sheet stop rods (2) are placed against the left- and right-hand side edge as well as against the rear edge of the stack.

The weight rods (3) on the left- and right-hand side must touch the corners of the stack.

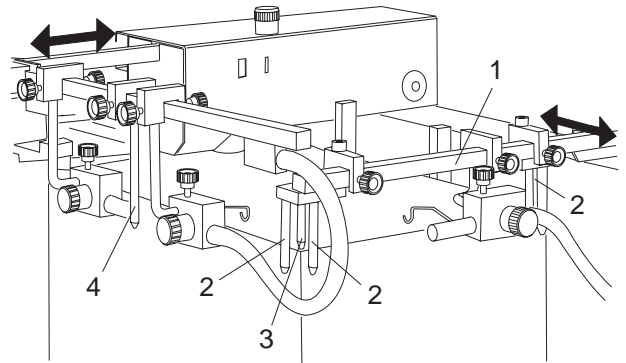

- Move the lateral cross-bar until the side stop (4) touches the stack.
- Adjust the air nozzles in such a way that they are approx. 1 to 2 cm away from the side - resp. rear edge.
- Adjust the angle of the air flow by turning the air nozzles so that about 10 sheets are separated.

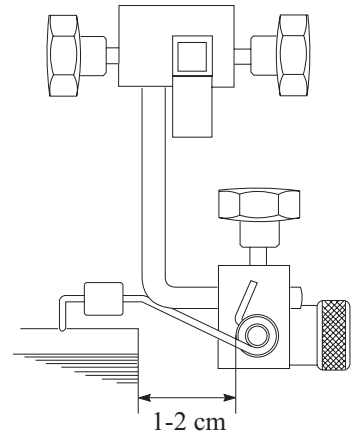

The amount of air can be fine-adjusted by means of valves (5).

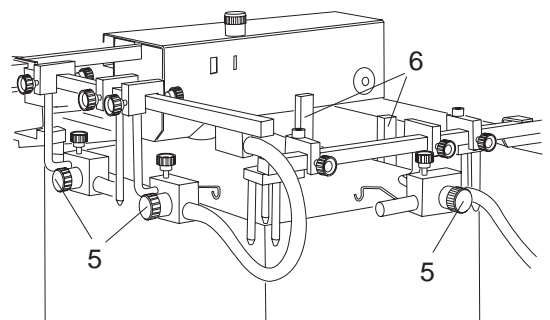

 The air cushion must not be so strong that the sheets under the suction drum are compressed.

Place the stop plate on the rear stops (6) so that an air cushion is created.

Side Stop, Right-hand Side

A special side stop at the right-hand side is part of the "side blower" kit. This stop should be used when the paper tends to drift sideways.

The side stop is attached to the arm of the suction wheel and can be moved sideways so that it can be set to the format width.

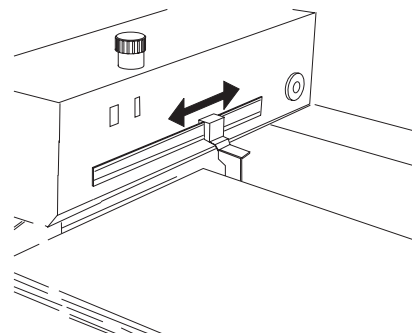

12. REGISTER TABLE

Setting the Format - Flat Pile Feeder

Register rail, ball cage and transport belt form one single unit and are adjusted together.



Make sure that the feeder is set to the correct format. Proceed as follows:

- Loosen the lock screw (1) of the register rail by turning it counter-clockwise.
- Turn the handwheel (2) until the paper stop pin (3) just touches the edge of the paper stack.
- Retighten the lock screw (1) by turning it clockwise.
- Set the rear paper support (11) to paper width, using the scale and pointer.
- Distribute the hold-down bars (5) across the sheet width. Place one hold-down bar in front of the suction drum (6).



If the paper is less than 15 - 16 cm wide, the paper guide plate (4) must be removed.

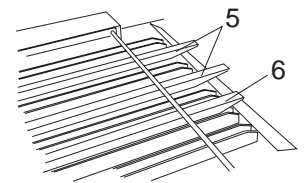
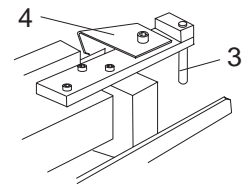
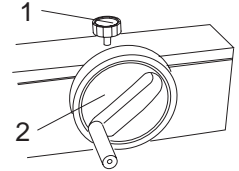

Setting the Format - Air Feeder PBA

- Loosen the lock screw (1) by turning it counter-clockwise.
- Set the alignment rail to the paper size by turning the handwheel (2). The scale at the fold roller infeed section (7) must show the same number as the scale on the feeder (8).

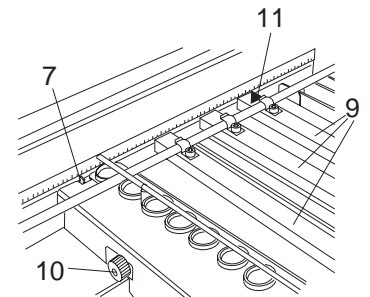
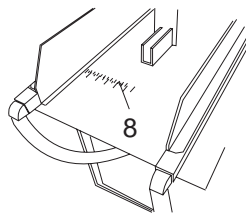

- Tighten the lock screw (1) by turning it clockwise.
- Distribute the hold-down bars (9) across the width of the sheet.

The infeed angle can be changed by means of the knurled screw (10) and the appropriate scale.

Type of Balls

The number and type of balls in the ball cage (1) depend on format and type of paper.



Always try to use as few balls as possible. Balls not needed for a particular job should be removed to avoid wear of the transport belt.

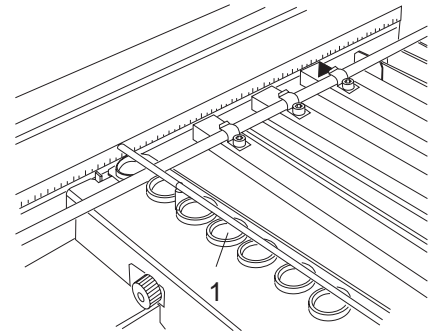

It is recommended to use the following balls:

Paper grades below 60 GSM:	Plastic balls
Paper grades from 60 - 150 GSM:	Plastic balls, every 6th should be a steel ball
Paper grades above 150 GSM:	Mainly steel balls

In the infeed section (the first 4 to 6 balls) it is recommended to always use one or two steel balls.

For very light paper grades every second ball opening should be left free.

13. BUCKLE FOLD UNITS

The buckle fold units multimaster CAS 38 have an infeed width of 38 cm and are generally equipped with 4 automatic fold plates AFT 38. The automation of these fold plates comprises the automatic positioning of the fold plate stops and the automatic closing of the deflectors. It is not necessary to remove the fold plates and to insert the deflectors when changing the fold.

Description

- 1 Noise covers
- 2 Fold roller adjustment knobs
- 3 Handwheel
- 4 Main switch
- 5 Operator panel
- 6 Transfer bridge
- 7 Roller table
- 8 Alignment rail
- 9 Fold rollers
- 10 Delivery shafts

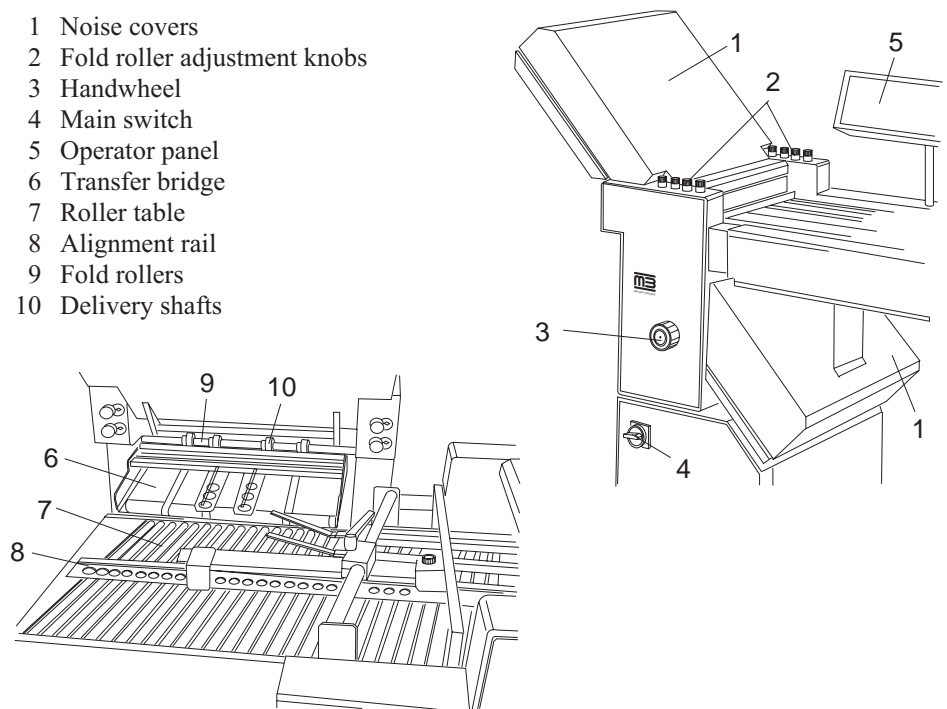

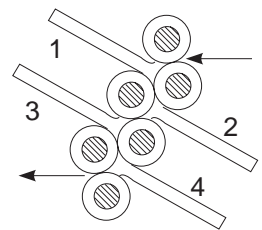

Fold Plate Positions

In the fold unit CAS 38/4 (1st or 2nd fold unit) there are four positions for the fold plates:

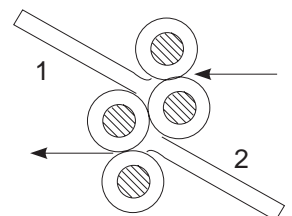

In the fold unit CAS 38/2 (2nd fold unit only) there are two positions for the fold plates:



 The fold plates are marked with a number. Care has to be taken that the fold plates are inserted in the correct positions, e.g. fold plate 1 in position 1, fold plate 2 in position 2, etc.

Installing the Fold Plates

The fold plates have one lock screw (1) each at the left- and right-hand side.

Insert the fold plates in such a way that the lock screws (1) fit in the recesses (2) in the frame of the fold unit.

Secure the fold plates by tightening the lock screws.

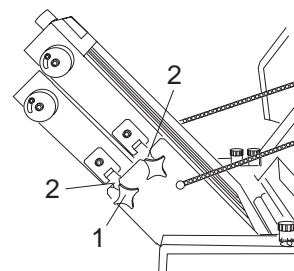

Connecting the Fold Plates

The electrical connection is done by means of special 90° plugs (3).

They are inserted at the front of the fold plates and secured by lightly tightening the threaded sleeve.

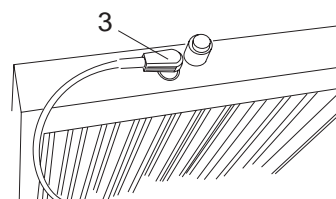

Make sure that the main switch is OFF before pulling or inserting the plug!



The number of the plug must agree with the number at the front side of the plate!

Setting Elements of the Fold Plates

- Knurled knob for angle corrections (4):

By turning the knurled knobs it is possible to make angle corrections of the paper stop, for example, if the paper is out-of-square.

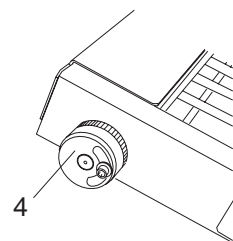

- Setting knob for adjusting the lower lip of the fold plates:
The lower lip can be adjusted by means of a setting knob in order to increase or decrease the space for forming the buckle, depending on paper thickness and paper stiffness. A scale indicates the positioning of the lower lip.

Basic position: "0" is flush with the top of the knob (5).
Lower lip advanced: Small buckle space (6), setting knob "-"
Lower lip set back: Large buckle space (7), setting knob "+"

- Thin paper grades: Advance the lower lip, "-"
- Heavy paper grades: Set back the lower lip, "+"

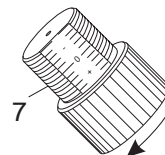
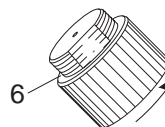
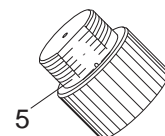

- Allen screws for changing the gap between the fold plate and the fold rollers:

For difficult-to-handle paper it is possible to set back the complete fold plate by up to 4 mm. For this two Allen screws (8) have to be loosened at the left and right side of the fold plate. A scale (9) facilitates precise setting.

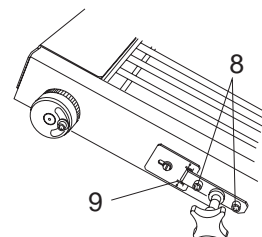

Setting the Fold Length

Setting the fold length and closing the deflectors is controlled by the computer. The respective commands are entered on the operator panel (see paragraph 16.)

14. ROLLER TABLE

Transfer Bridge

Folders with two fold units are always equipped with a transfer bridge (1). This bridge ensures the accurate transfer of the sheet onto the roller table.

Two ball cages guide the sheets.
Proceed as follows when changing the format:

- Loosen the clamp screws (2) by turning them counter-clockwise.
- Shift the ball cage in such a way that the balls run on a belt.
- Tighten the clamp screws by turning them clockwise.
- If necessary, the ball cages can also be moved in or out (loosen Allen screws (3) on both sides).

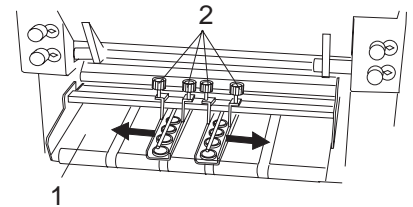

The angle of the bridge is adjustable and can therefore be adapted to the paper quality and the type of fold.

- Loosen the Allen screws (4) on both sides.
- Change the angle of the bridge.
- Tighten the Allen screws.

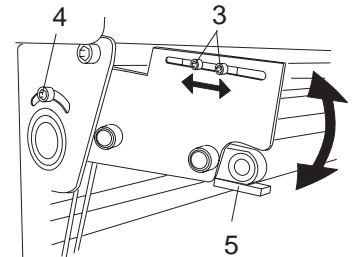

Make sure that the belts do not drag on the roller table!
Set the adjusting brackets (5) on both sides of the bridge accordingly.

Ejector Rollers

The ejector rollers on the delivery shafts must be set so that they are running on top of each other (6).

An adjustment is only necessary when the sheets are no longer guided properly after a change of format. To adjust:

- Turn the handwheel until the set screws of the ejector rollers are visible (7).
- Loosen the Allen screws with a 2-mm Allen key.
- Shift the ejector rollers to the required position.
- Tighten the Allen screws.

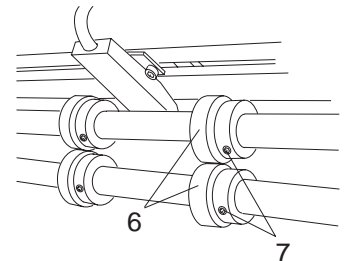

Register Rail

On the roller table, the sheets are transported to the next fold unit by means of rollers which are positioned at an angle with respect to the register rail. When changing the format, set the register rail as follows:

- Loosen the handle (1) by turning it counter-clockwise.
- Set the register rail (2) according to paper size with the help of the scale (3).
- Tighten the handle (1) by turning it clockwise.

The infeed angle can be adjusted at the knurled screw (4) with the appropriate locating screw (5) and scale (6).

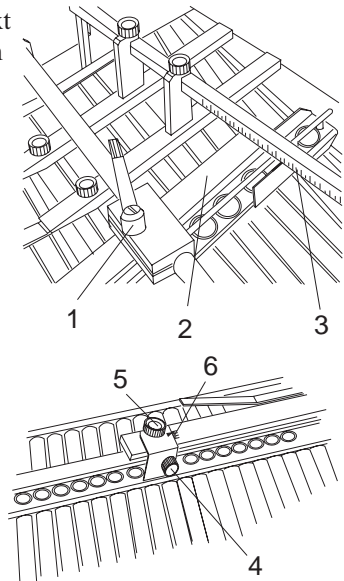

Hold-Down Bars

Hold-down bars (7, 8) prevent the sheets from jumping up during transport across the roller table.

- Loosen the knurled screws (9).
- Move the outer hold-down bar (7) in such a way that it is located over the outer edge of the sheet.
- Distribute the other hold-down bars over the width of the sheet.

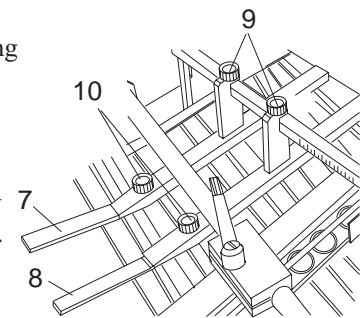

 By loosening knurled screws (10) the hold-downs can be extended for additional guiding.

Ball Cage

Load the ball cage (11) with plastic or steel balls. Type and number of balls depend on the format and type of paper.

 A minimum number of balls should always be used. Balls not needed for a particular job should be removed to reduce belt wear.

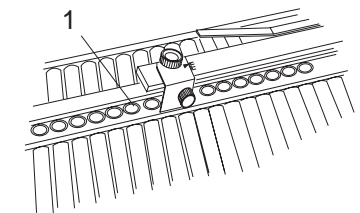

It is recommended to use the following balls:

- | | |
|---------------------------------|---|
| Paper grades below 60 GSM: | Plastic balls |
| Paper grades from 60 - 150 GSM: | Plastic balls, every 6th should be a steel ball |
| Paper grades above 150 GSM: | Mainly steel balls |

15. DELIVERIES AM 52, AMS 52, SKM 36

Fanned Deliveries AM 52, AMS 52

The fanned deliveries AM 52 and AMS 52 are mobile. Their height is adjustable by means of a gas-filled shock-absorber.

An additional control box (1) allows stopping and starting the machine (2) and paper feed (3) to facilitate setting the hold-down rollers.

Setting the Transfer Height

- Loosen the lock screw (4) by turning it counter-clockwise.
- Lift or lower the delivery table.
- Tighten the lock screw (4) by turning it clockwise.

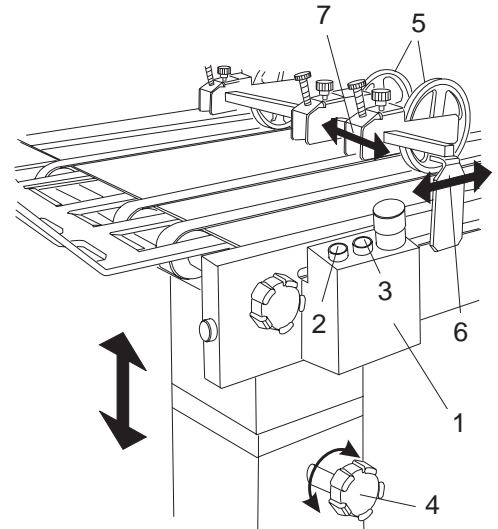

Setting the Format

The hold-down rollers (5) are needed for achieving a clean fanned delivery. They prevent the folded sheets from opening up on the delivery belt. The hold-down rollers are adjustable in two direction (6, 7).

 When moving them sideways make sure that the rollers always run on a delivery belt.

The distance between delivery shafts (8) and hold-down roller (9) should correspond to the sheet length of the folded sheet (10). To adjust, proceed as follows:

- Turn the setting wheel (11) to the left or to the right and shift the hold-down rollers to their new position.

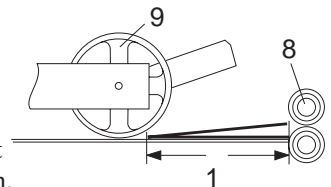

Pushing the button (12) will move the delivery belts for easy removal of sample sheets.

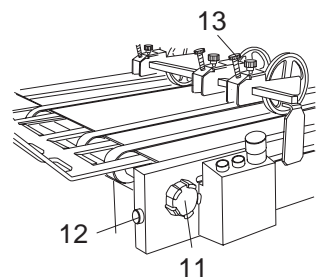

The pressure of the hold-down rollers can be changed by turning the knurled screws (13). Choose less pressure for thin paper below 80 GSM and more pressure for paper above 180 GSM.

Electrical Connection

The electrical connection of the delivery section is made by plugging the connecting cable into the socket (14) in the last fold unit.

 **When making or breaking any electrical connection, always first turn off the main switch or the safety switch of the folder. Non-compliance may cause damage to electronic components!**

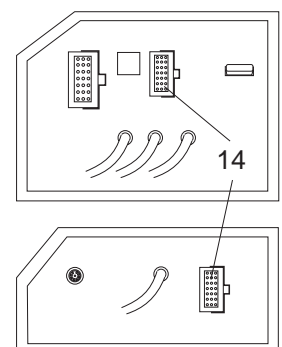

Small Format Vertical Stacker SKM 36

The vertical stacker is mobile and height-adjustable by means of a gas-filled shock absorber.

An additional control box (1) allows stopping and starting the machine (2) and paper feed (3) to facilitate setting the hold-down rollers.

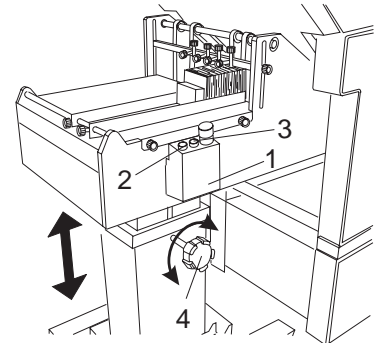

Setting the Transfer Height

- Loosen the handle (4) by turning it counter-clockwise.
- Lift or lower the delivery table.
- Tighten the handle by turning it clockwise.

Setting the Format

Support rails (5) and guide rails (6) are clamped to the cross rods by leaf springs. They are easily removable and can be moved to any position. Set for paper size as follows:

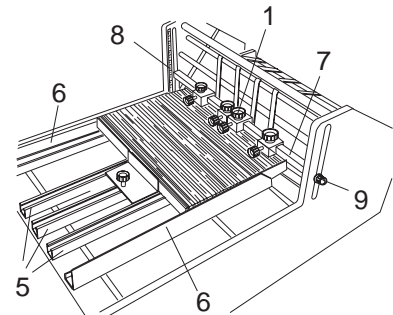

- Set the left and right guide rail (6) to paper width.
- Move the support rails (5) accordingly.
- Loosen the left and right clamp screws (9) and set the hold-down rail (7) to the height of the folded paper, using the scale (8). Retighten the clamp screws. Use screws (10) for fine tuning the hold-downs.

If the sheets are not guided properly by the transport belts after the setting, adjust them as follows:

- Loosen the Allen screws of the belt rollers (11).
- Distribute the belt rollers across the sheet width.
- Retighten the Allen screws.
- Set the idler rollers (12), belt tensioners (13) and the lower belts (14) to paper size.

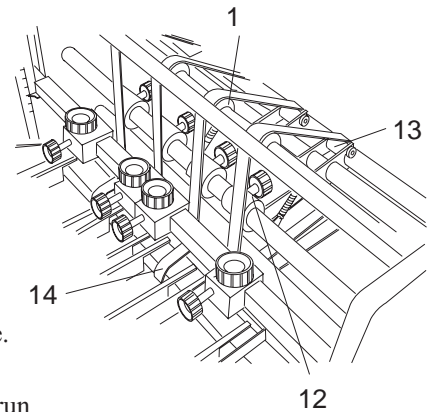

 The upper and lower belts must run on top of each other.

- Position the back-up plate (15) in the support rails.

 The back-up plate must be adjusted according to the folded stock size.

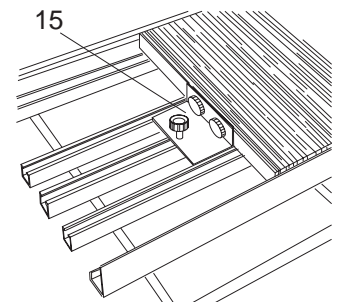

Setting the Paper Thickness

Use the setting wheels (1, 2) to set the gap between upper and lower belts to the thickness of the folded stock.



Move the setting wheels (1, 2) on either side by the same amount.

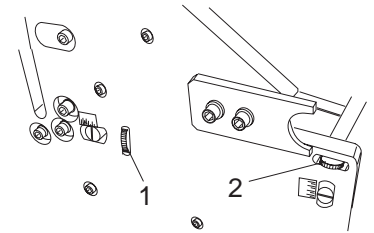

Positioning the Kicker

A kicker (3) can be added to the SKM 36. In order to use the kicker for counting batches, it must be set to paper size:

- Loosen the knurled screw (4).
- Move the kicker so it is positioned 5 mm away from the passing paper.
- Retighten the knurled screw (4).
- Position the stop (5) on the opposite side taking into account paper width and stroke of the kicker.
- Plug the cable from the kicker into the socket on the bottom of the stacker. This will cause the kicker to be recognized. The message **KICKER** appears in the display.
ON OFF

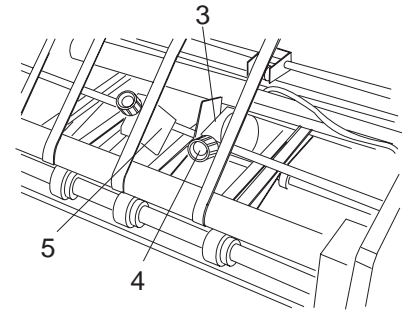

When making or breaking any electrical connection, always first turn off the main switch or the safety switch of the folder. Non-compliance may cause damage to electronic components!

16. AUTOMATIC SETTING

Operator Panel

The machines of the multimaster CAS 38 series are equipped with a central operator panel. It is here where the communication between operator and machine takes place and where all the important settings and monitoring functions are carried out.

The swing-around operator panel can be moved to the position which is most convenient for the operator.

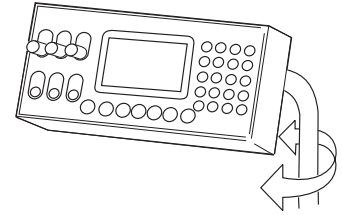

Description

Setting elements and keys with the following functions:

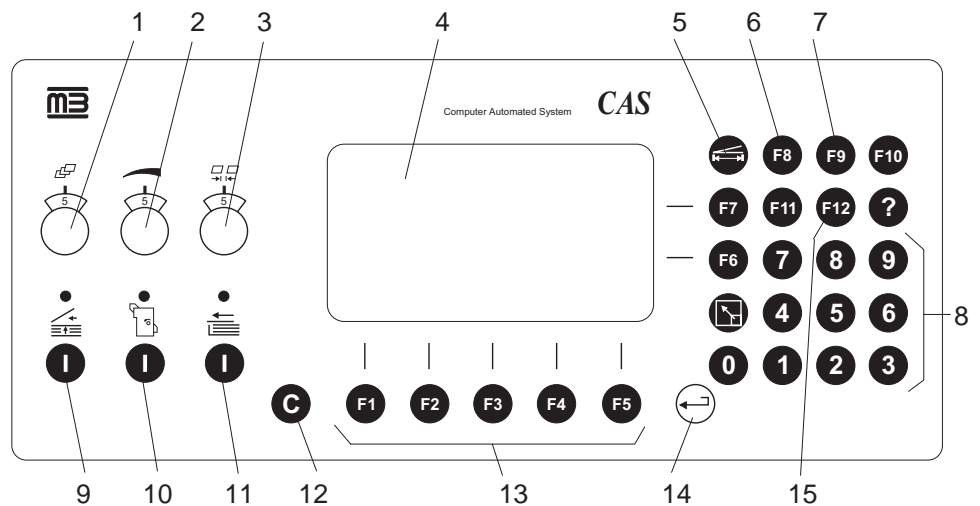

- 1 Sheet gap in delivery section
- 2 Fold speed
- 3 Sheet gap on the register table
- 4 Display
- 5 Display of menu FOLD LENGTH
- 6 Display of menu ROLLER GAP
- 7 Measuring system / language
- 8 Keys for numerical input
- 9 Pump
- 10 Fold roller drive
- 11 Sheet gap
- 12 Return to BASIC menu
- 13 Function keys for displaying different menus
- 14 Confirmation of a value entered
- 15 Information for service technician

Description of the Display

The operator panel contains an LC-display.
After switching on the machine, the following message appears:

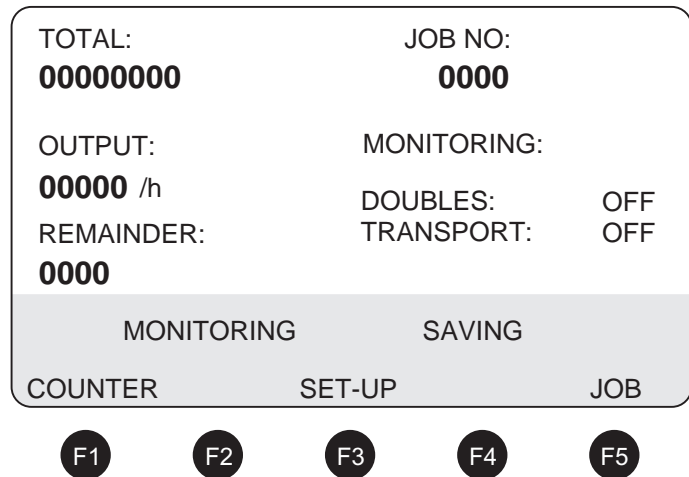

This display gives an overall view of the most important data.
For this reason the **BASIC** menu should always be called up when running the folder.



The displays for **TOTAL**, **OUTPUT**, **REMAINDER**, **DOUBLES**, **TRANSPORT** always refer to the actual folding job.

The **JOB NO** may refer to the actual folding job, but this is not necessarily the case.

When calling up the menu, the job number which was saved last or which was recalled from the memory is automatically displayed.

A job which was not saved cannot have an identification number and is therefore not displayed.

The following main menus can be chosen from the **BASIC** menu:

- **COUNTER** Setting of total and batch counting
- **MONITORING** Activation of double sheet detection and paper travel control
- **SET-UP** Automatic setting of fold lengths / Input of setting informations
- **SAVING** Saving of repetitive jobs
- **JOB** Actual folding job

A number of function keys (F1 to F7) with arrows pointing to the headlines of the main menu are grouped around the display.

By pressing one of these keys, the selected main menu is displayed.

Each menu is divided into a light and a dark section.
 Actual data is shown in the light section (1).
 In the dark section (2), additional menus are displayed, which can also be called up by pressing the function keys.
 The last line in the light section is the "command line" (3) and serves as an operator guide.
 This "command line" is very important because it indicates which command must be carried out next.

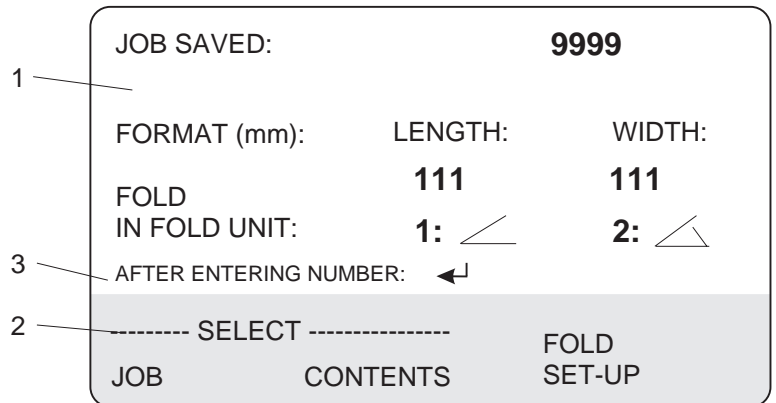

The keys on the operator panel are secured against incorrect operation, which means that malfunctions caused by unacceptable inputs or accidental pressing of keys will be prevented. Keys that are not used are automatically made inactive.

To help you familiarize yourself with this new system, the commands of the most important settings are explained step by step on the following pages. The sequence of the commands is shown by numbered input lines (4) so you will quickly understand the logic of the procedure.

Examples:

- 4 → 1. Press key C The BASIC menu is displayed.
- 4 → 2. Press key F3 The SET-UP menu is displayed.

By following the sequence shown and observing the instructions, you will soon master the operation of the machine and benefit from the advantages of the computer control.



If you get confused while entering commands, simply return to the BASIC menu by pressing key C and start again.

The following operating instructions are arranged in such a way that all main menus are described, starting with COUNTER and finishing with JOB.

Setting the Counter - Main Menu COUNTER

1. Press key C The BASIC menu is displayed.

TOTAL: 00000000	JOB NO: 0000
OUTPUT: 00000 /h	MONITORING:
REMAINDER: 0000	DOUBLES: OFF
	TRANSPORT: OFF
MONITORING SAVING	
COUNTER	SET-UP JOB

F1 F2 F3 F4 F5

2. Press key F1 The COUNTER menu is displayed.

The figures in the display refer to a previous folding job.

COUNTER	
BATCH:	0111
INTERVAL:	11
TOTAL:	00000111
AFTER ENTERING NUMBER:	←
SELECT	CLEAR TOTAL

F1 F4

Clearing the Total Counter

3. Press key F4 The total counter is cleared.

COUNTER	
BATCH:	0111
INTERVAL:	11
TOTAL:	00000000
AFTER ENTERING NUMBER:	←
SELECT	CLEAR TOTAL

F1 F4

Setting the Batch Counter

The dark background of the line **BATCH** means that the preselected number of sheets per batch can be entered.

The batch counter is used to mark a pre-selected number of sheets (batch) in such a way that it can be separated from the next batch. This makes it easy to remove the individual batches from the delivery table. The following data must be entered for batch counting:

- the desired number of sheet per batch (preselection)
- the length of the gap (interval) between batches

Example: Batches of 50 sheets.

4. Enter the number of sheets (e.g 50) The new BATCH is displayed.

COUNTER	
BATCH:	0050
INTERVAL:	11
TOTAL:	00000000
AFTER ENTERING NUMBER:	←
SELECT	CLEAR TOTAL

F1

F4

5. Press key ← The new batch is saved.

COUNTER	
BATCH:	0050
INTERVAL:	11
TOTAL:	00000000
AFTER ENTERING NUMBER:	←
SELECT	CLEAR TOTAL

F1

F4

The dark background of the line **INTERVAL** means that the interval needed for batch counting can be entered.

Example: The gap between batches (interval) in the delivery section should be as long as it takes to feed 4 sheets.

6. Enter the interval (e.g. 4) The new INTERVAL is displayed.

COUNTER	
BATCH:	0050
INTERVAL:	04
TOTAL:	00000000
AFTER ENTERING NUMBER:	←
SELECT	CLEAR TOTAL

F1
F4

7. Press key ← The new interval is saved.

COUNTER	
BATCH:	0050
INTERVAL:	04
TOTAL:	00000000
AFTER ENTERING NUMBER:	←
SELECT	CLEAR TOTAL

F1
F4

The dark background moves again back to the BATCH line. By pressing key F1 it is possible to alternate between BATCH and INTERVAL lines.



When batch counting is not used, enter "0" for BATCH or INTERVAL.

8. Press key C Back to BASIC menu.

Set Kicker for Batch Counting

The kicker serves to mark a preselected number of sheets (batch) by pushing the last sheet sideways, which makes it easy to distinguish between the individual batches.



The kicker is used in conjunction with a small format vertical stacker SKM 36.



The plug of the kicker must be connected to the socket at the bottom of the vertical stacker for small formats.

1. Press key C The BASIC menu is displayed.

TOTAL: 00000000	JOB NO: 0000
OUTPUT: 00000 /h	MONITORING:
REMAINDER: 0000	DOUBLES: OFF
	TRANSPORT: OFF
MONITORING SAVING	
COUNTER	SET-UP JOB

F1 F2 F3 F4 F5

2. Press key F1 The COUNTER menu is displayed.

COUNTER	
BATCH:	0111
INTERVAL:	11
TOTAL:	00000111
AFTER ENTERING NUMBER:	←
KICKER CLEAR	
SELECT	ON OFF TOTAL

F1 F2 F3 F4

3. Press key F2 The kicker is switched on.

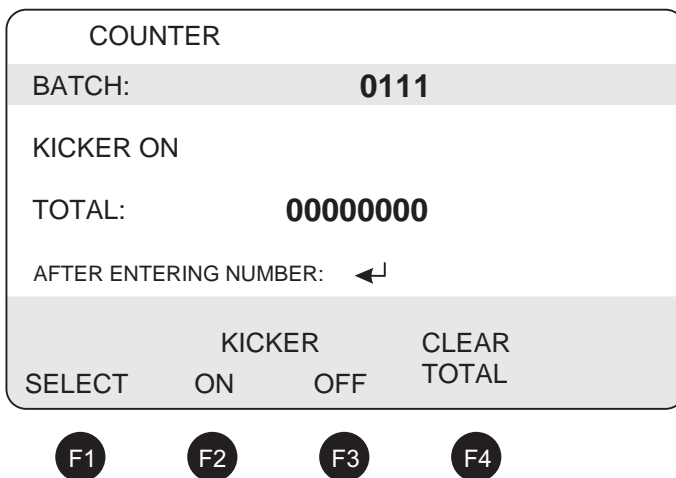

The display INTERVAL changes to KICKER ON.

Example: Batches of 50 sheets.

4. Enter the number of sheets (e.g. 50) The new BATCH is displayed.

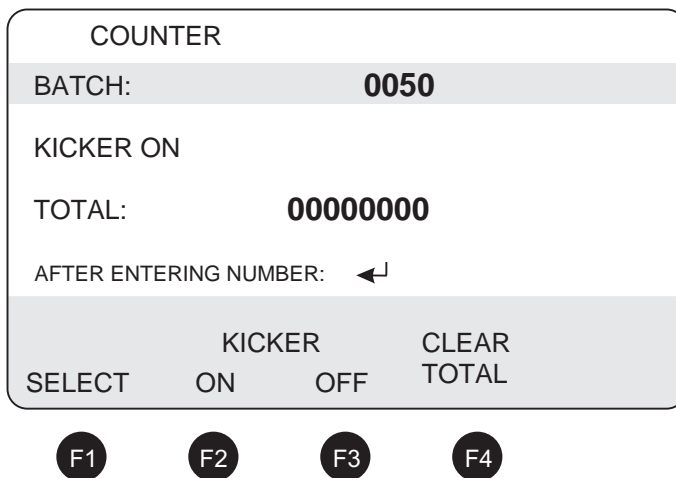

5. Press key ← The new batch is saved.

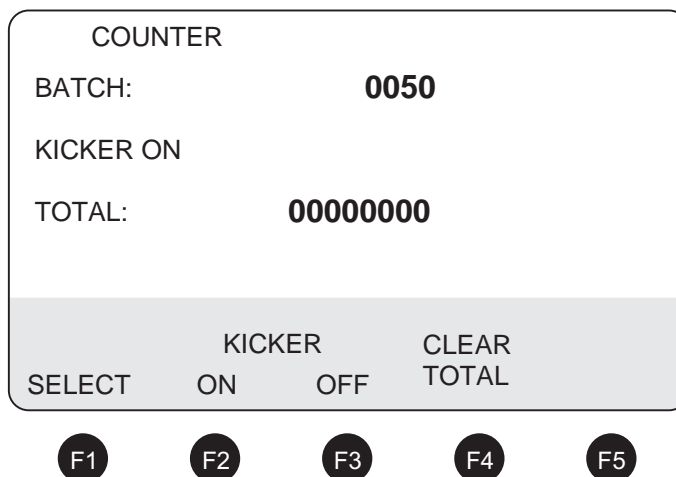

6. Press key C Back to BASIC menu.

TOTAL: 00000000	JOB NO: 0000
OUTPUT: 00000 /h	KICKER ON
REMAINDER: 0000	MONITORING:
	DOUBLES: OFF
	TRANSPORT: OFF
MONITORING SAVING	
COUNTER	SET-UP JOB

F1

F2

F3

F4

F5

In Menu BASIC, the display KICKER ON below the JOB NO shows that the kicker is active.



When working with a fanned delivery, the kicker cannot be used.

Paper Transport Control, Double Sheet Detection - Main Menu MONITORING

1. Press key C The BASIC menu is displayed.

TOTAL: 00000000	JOB NO: 0000			
OUTPUT: 00000 /h	MONITORING:			
REMAINDER: 0000	DOUBLES: OFF			
	TRANSPORT: OFF			
MONITORING SAVING				
COUNTER	SET-UP	JOB		
F1	F2	F3	F4	F5

2. Press key F2 The MONITORING menu is displayed.

MONITORING			
DOUBLES:		OFF	
TRANSPORT:		OFF	
SWITCH ON / OFF			
DOUBLES		TRANSPORT	
ON	OFF	ON	OFF
F1	F2	F4	F5

Paper Transport Control

3. Press key F4 The paper transport control is active.

MONITORING			
DOUBLES:		OFF	
TRANSPORT:		ON	
SWITCH ON / OFF			
DOUBLES		TRANSPORT	
ON	OFF	ON	OFF
F1	F2	F4	F5

Double Sheet Detection

4. Press key F1

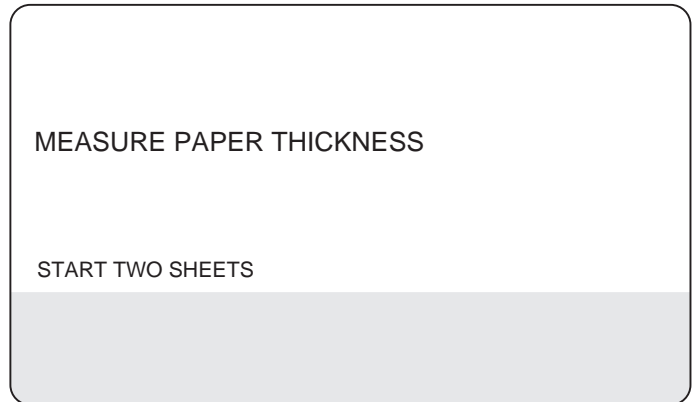

Prior to switching the machine on, it must be set-up and the feeder must be loaded with paper.

5. Switch on pump and main motor. Press the sheet transport key (1x).

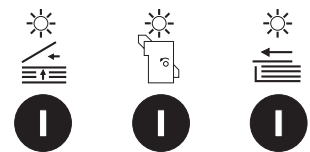

6. Press the sheet transport key (1x). The paper thickness is displayed.

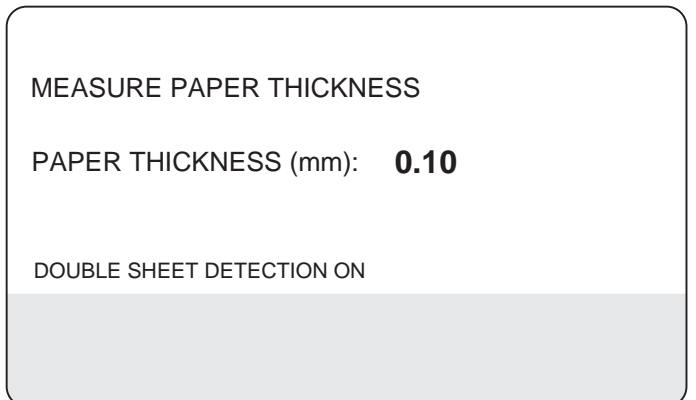

7. Switch off the main motor and the pump.

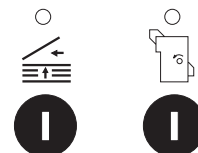

8. Press key C Back to BASIC menu.



If the double sheet detection or the paper transport control is to be deactivated, the CONTROL menu must be called up by pushing key F2 in the BASIC menu - then push key F2 or F5.

Setting the Fold Length - Main Menu SET-UP

The automatic setting of the multimaster CAS 38 makes it possible that all stops - driven by timing belts and servo motors - are set automatically to the position calculated by the computer.

The fold plates which are not used for a particular folding job are automatically closed by deflectors and always remain in the fold unit.

The fold plate stops can be set in three different ways:

1. Automatic setting of pre-programmed standard folds
2. Entering the fold lengths individually on the keyboard - Special folds
3. Calling up fold programs from the memory - Job saved

Standard Folds

For this type of setting, it is not necessary to make a sample fold by hand and to measure it. Just enter the required type of fold.

The following standard folds are permanently programmed in the software:

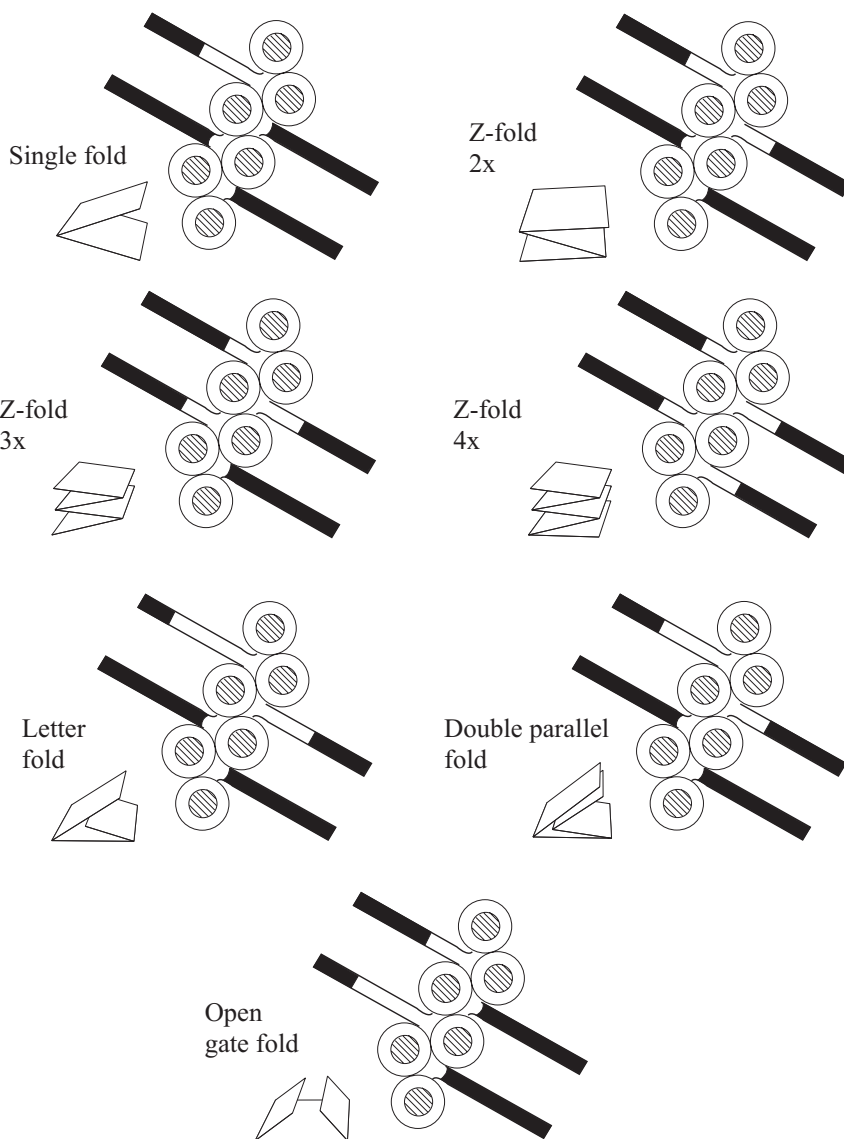

1. Press key C The BASIC menu is displayed.

TOTAL: 00000000	JOB NO: 0000
OUTPUT: 00000 /h	MONITORING:
REMAINDER: 0000	DOUBLES: ON TRANSPORT: ON
MONITORING SAVING	
COUNTER	SET-UP JOB







F1 F2 F3 F4 F5

2. Press key F3 The SET-UP menu is displayed.

SET-UP SELECT WITH FUNCTION KEYS	
SUCTION LENGTH →	F7
JOB SAVED →	F6
----- FOLD -----	
SPECIAL STANDARD	ROLLER DELI- GAP VERY

F1 F2 F4 F5

3. Press key F2 The STANDARD FOLDS menu is displayed.

STANDARD FOLDS		
FOLD UNIT:	1	
      		
AFTER SELECTING FOLD:	←	
FOLD UNIT	FOLD	SET-UP

F1 F3 F5



Pressing key F3 several times will shift the cursor (dark rectangle) from one symbol to the other.

Setting example: A DIN A3 (297 x 420 mm) sheet is to be folded as follows:

First fold unit: Z-fold  Second fold unit: Letter fold 

4. Press key F3 until the respective fold symbol for the first fold unit (Z-fold) is marked by the cursor.

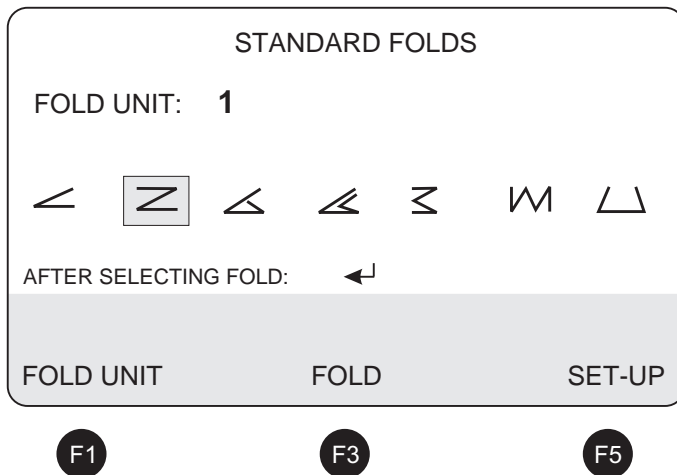

5. Press key  The selected fold is confirmed.

The format length of a previous job is shown in the display.

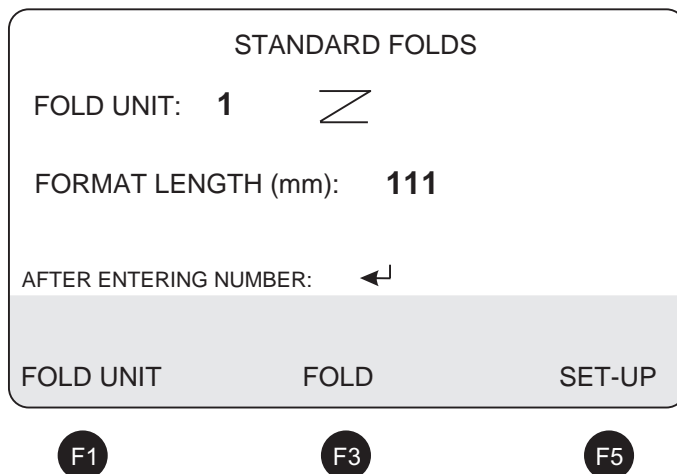

6. Enter the format length (420) The new format length is displayed.

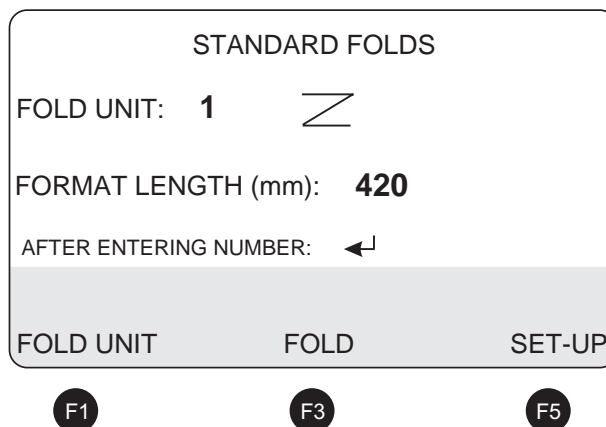

If a format is entered that cannot be handled by the machine because it is too small or too large, this is recognized by the computer and shown in the display.

7. Press key  The new format length is saved.

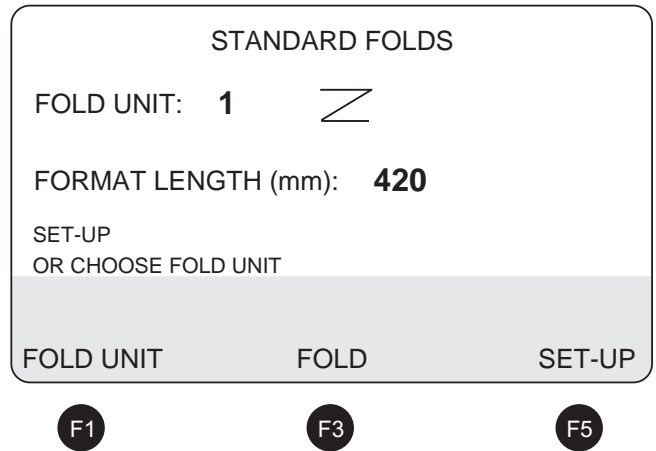

8. Press key F1 The second fold unit is selected.

Since, in our example, a letter fold is to be made in the second fold unit, the cursor must be shifted to the respective fold symbol.

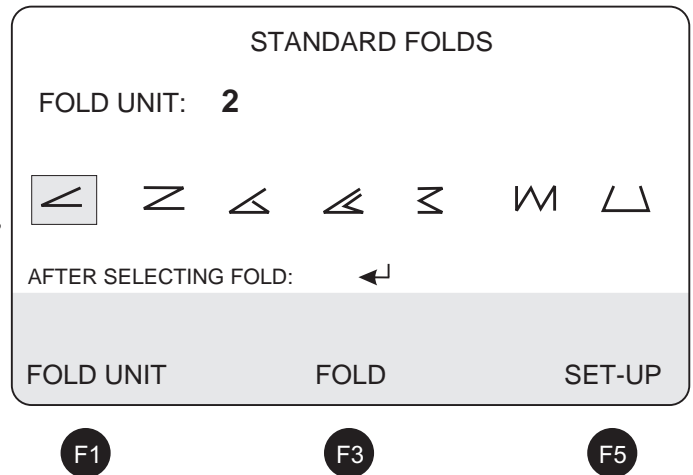

9. Press key F3 repeatedly until the respective fold symbol for the second fold unit (letter fold) is marked by the cursor.

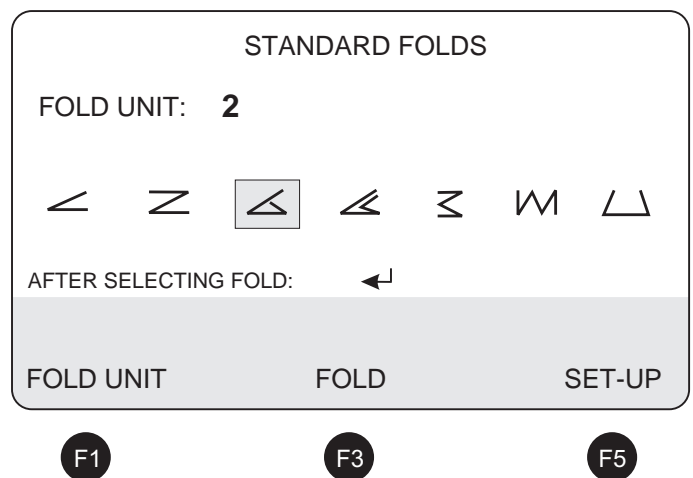

10. Press key  The new format length is saved.

The format width of a previous job is shown in the display.

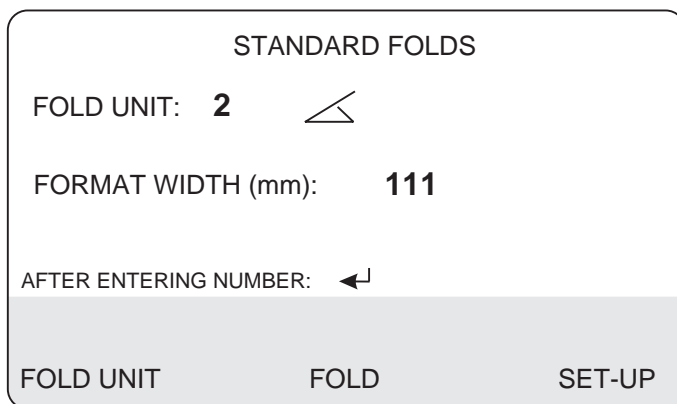

F1

F3

F5

11. Enter format width (297) The new format width is displayed.

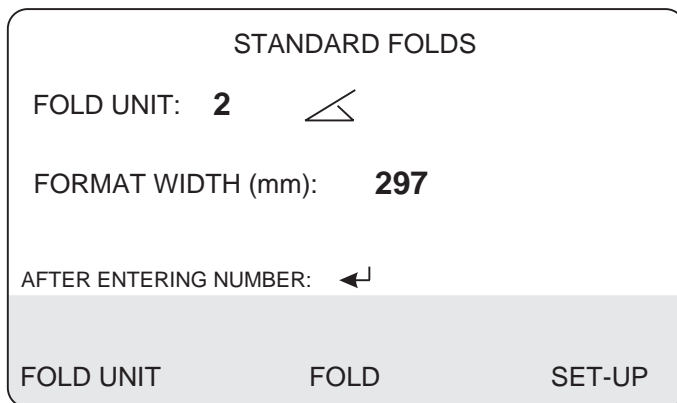

F1

F3

F5

 If a format is entered that cannot be handled by the machine because it is too small or too large, this is recognized by the computer and shown in the display.

12. Press key 

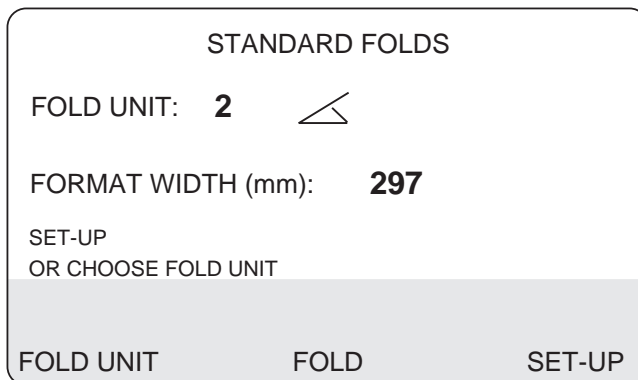

F1

F3

F5

13. Press key F5 The stops are positioned automatically and the fold plates not needed are closed by deflectors.

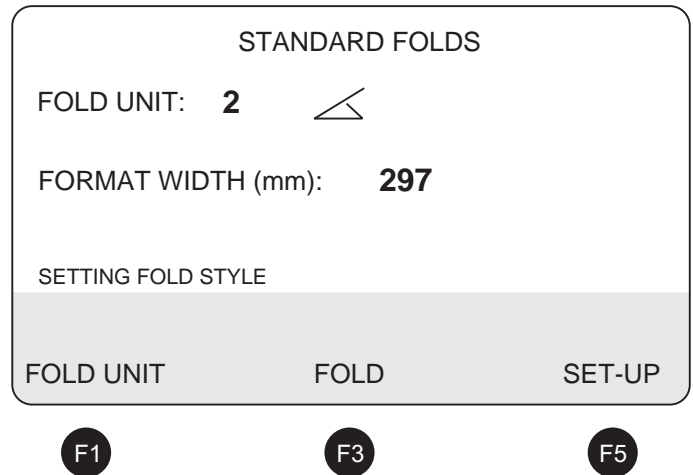

 The display **SETTING FOLD STYLE** is flashing until the setting process is completed. Then the following message appears:

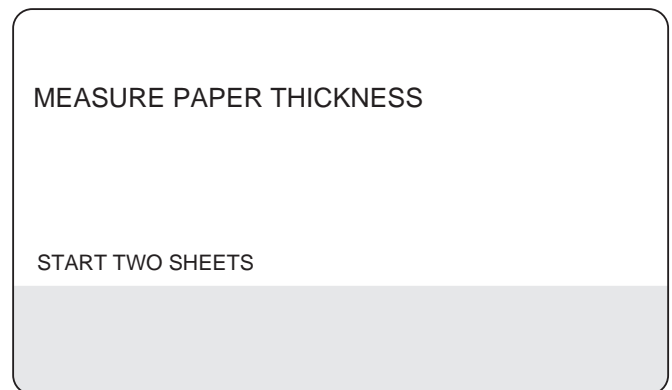

 Prior to switching the machine on, it must be set up and the feeder must be loaded with paper.

14. Switch on pump and main motor, press the sheet transport key (1x).

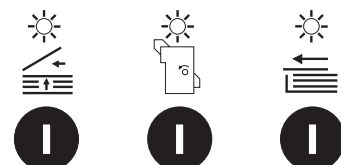

15. Press the sheet transport key (1x) The paper thickness is displayed.

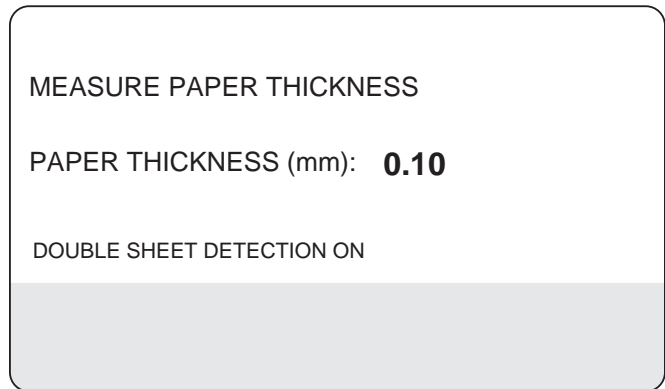

After a few seconds the display returns to the SET-UP menu.

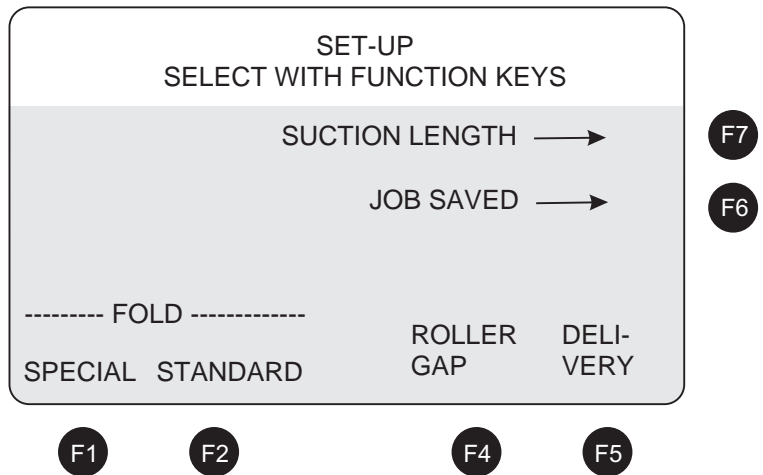

16. Switch off main motor and pump.

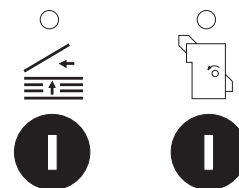

17. Press key C Back to BASIC menu.

Special Folds

This kind of set-up resembles most the principle used in conventional folding machines because the fold length of each stop must be calculated or measured before setting. The actual setting, however, is done at the operator panel.

1. Press key C The BASIC menu is displayed.

TOTAL: 00000000	JOB NO: 0000	
OUTPUT: 00000 /h	MONITORING:	
REMAINDER: 0000	DOUBLES: ON	
	TRANSPORT: ON	
MONITORING		SAVING
COUNTER	SET-UP	JOB

F1 F2 F3 F4 F5

To enter the measurements for the fold lengths, e.g. to set the fold plate stops, the menu SET-UP must be called up via key F3.

2. Press key F3 The SET-UP menu is displayed.

SET-UP SELECT WITH FUNCTION KEYS			
SUCTION LENGTH →			F7
JOB SAVED →			F6
----- FOLD -----			
SPECIAL	STANDARD	ROLLER GAP	DELI- VERY

F1 F2 F4 F5

3. Press key F1 The SET-UP SPECIAL FOLD menu for fold unit 1 is displayed.

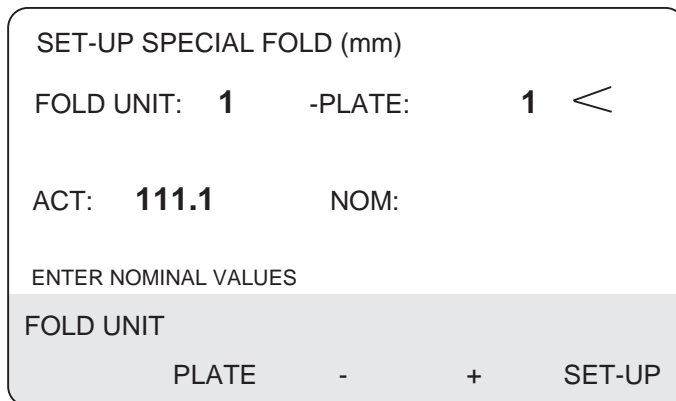

The display shows ACT (Actual) as the current fold length (e.g. 111.1) and the matching fold symbol, e.g. <, ≧, ...

Example: A sheet in format DIN A3 (297 x 420 mm) is to be folded.

First fold unit: Z-fold ≧
Second fold unit: Letter fold ≡

This translates into the following fold plate settings:

1st fold unit (Z-fold)
Fold plate 1: 140 mm
Fold plate 2: 141 mm
Fold plate 3: 0 mm
Fold plate 4: 0 mm

2nd fold unit (Letter fold)
Fold plate 1: 198 mm
Fold plate 2: 99 mm
Fold plate 3: 0 mm
Fold plate 4: 0 mm

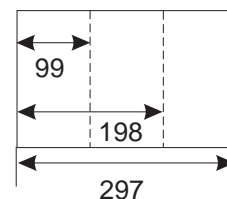
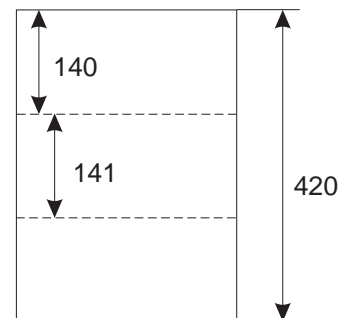

4. Enter the fold length for the first fold unit, first fold plate Example: 140

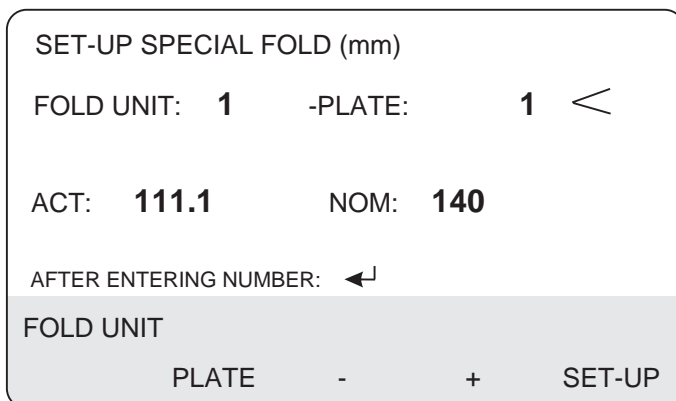

5. Press key \leftarrow The fold length is saved.

SET-UP SPECIAL FOLD (mm)

FOLD UNIT: **1** -PLATE: **1** <

ACT: **111.1** NOM: **140**

ENTER NOMINAL VALUES

FOLD UNIT

PLATE	-	+	SET-UP
-------	---	---	--------

F1 F2 F3 F4 F5

6. Press key F2 Fold plate 1 is called up.

SET-UP SPECIAL FOLD (mm)

FOLD UNIT: **1** -PLATE: **2** <

ACT: **111.1** NOM:

ENTER NOMINAL VALUES

FOLD UNIT

PLATE	-	+	SET-UP
-------	---	---	--------

F1 F2 F3 F4 F5

7. Enter fold length for the first fold unit, second fold plate Example: 141

SET-UP SPECIAL FOLD (mm)

FOLD UNIT: **1** -PLATE: **2** <

ACT: **111.1** NOM: **141**

AFTER ENTERING NUMBER: \leftarrow

FOLD UNIT

PLATE	-	+	SET-UP
-------	---	---	--------

F1 F2 F3 F4 F5

8. Press key \leftarrow The fold length is saved.

SET-UP SPECIAL FOLD (mm)				
FOLD UNIT:	1	-PLATE:	2	<
ACT:	111.1	NOM:	141	
ENTER NOMINAL VALUES				
FOLD UNIT				
	PLATE	-	+	SET-UP
F1	F2	F3	F4	F5

9. Press key F2 Fold plate 3 is called up.

SET-UP SPECIAL FOLD (mm)				
FOLD UNIT:	1	-PLATE:	3	<
ACT:	111.1	NOM:		
ENTER NOMINAL VALUES				
FOLD UNIT				
	PLATE	-	+	SET-UP
F1	F2	F3	F4	F5

10. Enter fold length for the first fold unit, third fold plate Example: 0

SET-UP SPECIAL FOLD (mm)				
FOLD UNIT:	1	PLATE:	3	<
ACT:	111.1	NOM:	000	
AFTER ENTERING NUMBER: \leftarrow				
FOLD UNIT				
	PLATE	-	+	SET-UP
F1	F2	F3	F4	F5

11. Press key ← The fold length is saved.

SET-UP SPECIAL FOLD (mm)

FOLD UNIT: **1** PLATE: **3** <

ACT: **111.1** NOM: **000**

ENTER NOMINAL VALUES

FOLD UNIT

PLATE - + SET-UP

F1 F2 F3 F4 F5

12. Press key F2 Fold plate 4 is called up.

SET-UP SPECIAL FOLD (mm)

FOLD UNIT: **1** -PLATE: **4** <

ACT: **111.1** NOM:

ENTER NOMINAL VALUES

FOLD UNIT

PLATE - + SET-UP

F1 F2 F3 F4 F5

13. Enter fold length for the first fold unit, fourth fold plate Example: 0

SET-UP SPECIAL FOLD (mm)

FOLD UNIT: **1** -PLATE: **4** <

ACT: **111.1** NOM: **000**

AFTER ENTERING NUMBER: ←

FOLD UNIT

PLATE - + SET-UP

F1 F2 F3 F4 F5

14. Press key ← The fold length is saved.

SET-UP SPECIAL FOLD (mm)

FOLD UNIT: **1** -PLATE: **4** <

ACT: **111.1** NOM: **000**

ENTER NOMINAL VALUES

FOLD UNIT

PLATE - + SET-UP

F1 F2 F3 F4 F5

Now the fold lengths for all 4 fold plates of the first fold unit are entered.

15. Press key F1 The second fold unit is displayed.

SET-UP SPECIAL FOLD (mm)

FOLD UNIT: **2** -PLATE: **1** <

ACT: **111.1** NOM:

AFTER ENTERING NUMBER: ←

FOLD UNIT

PLATE - + SET-UP

F1 F2 F3 F4 F5

16. Enter fold length for the second fold unit, first fold plate Example: 198

SET-UP SPECIAL FOLD (mm)

FOLD UNIT: **2** -PLATE: **1** <

ACT: **111.1** NOM: **198**

AFTER ENTERING NUMBER: ←

FOLD UNIT

PLATE - + SET-UP

F1 F2 F3 F4 F5

17. Press key **←** The fold length is saved.

SET-UP SPECIAL FOLD (mm)

FOLD UNIT: **2** -PLATE: **1** <

ACT: **111.1** NOM: **198**

ENTER NOMINAL VALUES

FOLD UNIT

PLATE - + SET-UP

F1
F2
F3
F4
F5

18. Press key **F2** Fold plate 2 is called up.

SET-UP SPECIAL FOLD (mm)

FOLD UNIT: **2** -PLATE: **2** <

ACT: **111.1** NOM:

ENTER NOMINAL VALUES

FOLD UNIT

PLATE - + SET-UP

F1
F2
F3
F4
F5

19. Enter fold length for second fold unit, second fold plate Example: 99

SET-UP SPECIAL FOLD (mm)

FOLD UNIT: **2** PLATE: **2** <

ACT: **111.1** NOM: **99**

AFTER ENTERING NUMBER: **←**

FOLD UNIT

PLATE - + SET-UP

F1
F2
F3
F4
F5

20. Press key **←** The fold length is saved.

SET-UP SPECIAL FOLD (mm)

FOLD UNIT: **2** -PLATE: **2** <

ACT: **111.1** NOM: **99**

ENTER NOMINAL VALUES

FOLD UNIT

PLATE - + SET-UP

F1 F2 F3 F4 F5

21. Press key **F2** Fold plate 3 is called up.

SET-UP SPECIAL FOLD (mm)

FOLD UNIT: **2** -PLATE: **3** <

ACT: **111.1** NOM:

ENTER NOMINAL VALUES

FOLD UNIT

PLATE - + SET-UP

F1 F2 F3 F4 F5

22. Enter fold length for second fold unit, third fold plate Example: 0

SET-UP SPECIAL FOLD (mm)

FOLD UNIT: **2** PLATE: **3** <

ACT: **111.1** NOM: **000**

AFTER ENTERING NUMBER: **←**

FOLD UNIT

PLATE - + SET-UP

F1 F2 F3 F4 F5

23. Press key \leftarrow The fold length is saved.

SET-UP SPECIAL FOLD (mm)

FOLD UNIT: **2** -PLATE: **3** <

ACT: **111.1** NOM: **000**

ENTER NOMINAL VALUES

FOLD UNIT

PLATE - + SET-UP

F1
F2
F3
F4
F5

24. Press key F2 Fold plate 4 is called up.

SET-UP SPECIAL FOLD (mm)

FOLD UNIT: **2** -PLATE: **4** <

ACT: **111.1** NOM:

ENTER NOMINAL VALUES

FOLD UNIT

PLATE - + SET-UP

F1
F2
F3
F4
F5

25. Enter fold length for the second fold unit, fourth fold plate Example: 0

SET-UP SPECIAL FOLD (mm)

FOLD UNIT: **2** -PLATE: **4** <

ACT: **111.1** NOM: **000**

AFTER ENTERING NUMBER: \leftarrow

FOLD UNIT

PLATE - + SET-UP

F1
F2
F3
F4
F5

26. Press key  The fold length is saved.

When all fold lengths have been entered, the next step is the command for automatic setting of the stops.

SET-UP SPECIAL FOLD (mm)

FOLD UNIT: **2** PLATE: **4** <

ACT: **111.1** NOM: **000**

ENTER NOMINAL VALUES

FOLD UNIT

PLATE - + SET-UP

F1
F2
F3
F4
F5

27. Press key F5

SET-UP SPECIAL FOLD (mm)

FOLD UNIT: **2** PLATE: **4** <

ACT: **111.1** NOM: **000**

SETTING FOLD STYLE

FOLD UNIT

PLATE - + SET-UP

F1
F2
F3
F4
F5

 The display **SETTING FOLD STYLE** is flashing until the setting is completed. Then the following display appears:

MEASURE PAPER THICKNESS

START TWO SHEETS

 Prior to switching the machine on, it must be set up and the feeder must be loaded with paper.

28. Switch on pump and main motor. Press the sheet transport key (1x).

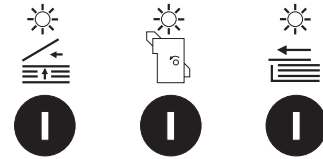

29. Press the sheet transport key (1x) The paper thickness is displayed.



After a few seconds the display returns to the SET-UP menu.

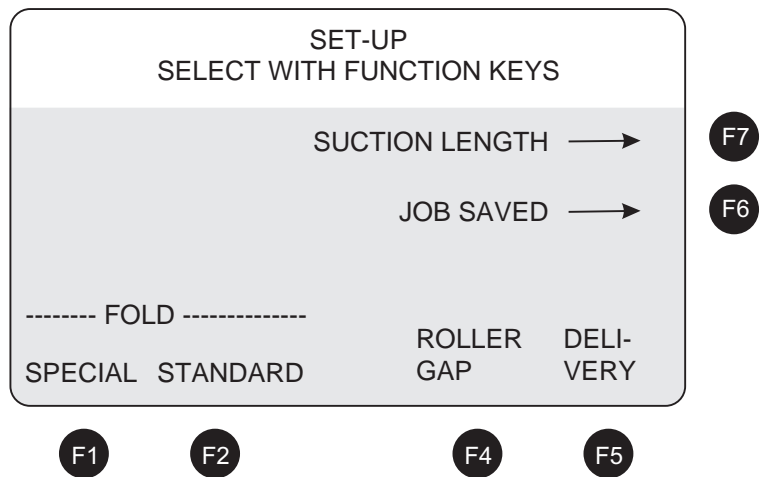

30. Switch off the main motor and the pump.

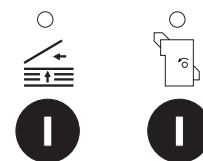

31. Press key C Back to BASIC menu.

Job Saved

A job can be recalled from memory only when the identification number (memory- or job number) is known.

If the number is unknown, it is possible to display the contents of the memory and thus find the number.

Entering the Memory/Job Number

1. Press key C The BASIC menu is displayed.

TOTAL: 00000000	JOB NO: 0000	
OUTPUT: 0000 /h	MONITORING:	
REMAINDER: 0000	DOUBLES: ON	
	TRANSPORT: ON	
MONITORING		SAVING
COUNTER	SET-UP	JOB

F1 F2 F3 F4 F5

In order to set up a job from the memory, the SET-UP menu must be called up by pressing key F3.

2. Press key F3 The SET-UP menu is displayed.

SET-UP SELECT WITH FUNCTION KEYS		
	SUCTION LENGTH →	F7
	JOB SAVED →	F6
----- FOLD -----		
SPECIAL	STANDARD	ROLLER DELI- GAP VERY

F1 F2 F4 F5

3. Press key F6 The JOB SAVED menu is displayed.

JOB SAVED:		1111
FORMAT (mm):	LENGTH:	WIDTH:
	111	111
FOLD IN FOLD UNIT	1: \angle	2: \sphericalangle
AFTER ENTERING NUMBER: \leftarrow		
----- SELECT -----		FOLD SET-UP
JOB	CONTENTS	

F1
F3
F4

The display shows the number of the job which was last saved or recalled from the memory. If another job is to be set up, enter the number under which it is saved.

Example: A crossfold DIN A3 (297 x 420 mm) was saved under job number 9999. This fold is to be set up again.

4. Enter the job number Example: 9999

JOB SAVED:		9999
FORMAT (mm):	LENGTH:	WIDTH:
	111	111
FOLD IN FOLD UNIT	1: \angle	2: \sphericalangle
AFTER ENTERING NUMBER: \leftarrow		
----- SELECT -----		FOLD SET-UP
JOB	CONTENTS	

F1
F3
F4

The length and width still refer to the previous job.

5. Press key ← The format and fold are displayed.

JOB SAVED:		9999
FORMAT (mm):	LENGTH:	WIDTH:
	420	297
FOLD IN FOLD UNIT	1: ∠	2: ∠
----- SELECT -----		FOLD SET-UP
JOB	CONTENTS	



The next input depends on what values are to be taken over from memory:

- Fold lengths only → continue with key F4
*This key is pressed if the new job uses the same paper size and fold, but a **different paper weight.***
- Fold lengths, suction length as well as setting values for fanned delivery, fold speed, fold roller gap and sheet gap → continue with key F3
*This key is pressed if the new job uses the same paper size, fold and the **same paper weight.***

The following example assumes that the new job uses the same paper weight and that all values have to be called up for that reason.

6. Press key F3 The CONTENTS menu is displayed.

JOB SAVED:		9999
DELIVERY	SPEED	SHEET GAP
07	08	06
MANUAL SETTING		
----- SELECT -----		FOLD SET-UP
JOB	CONTENTS	



7. These figures must be entered manually by turning the knobs with the corresponding controls.

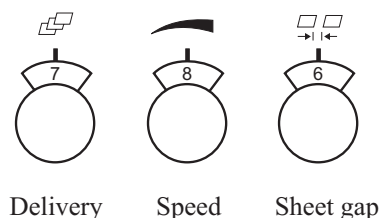

8. Press key F3 Display ROLLER GAP.

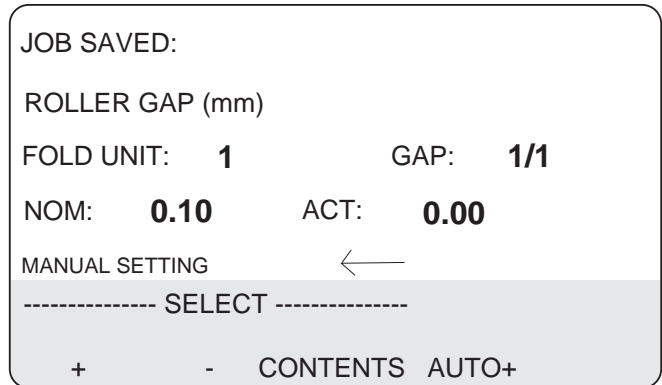

For correct setting of the fold rollers the ACT (Actual) value must be changed to the NOM (Nominal) value. This is done by turning the setting knobs (1).

 The displayed NOM corresponds to the value that was set during the saving process (individual corrections are taken into account).

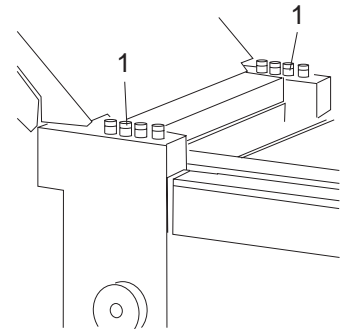

All setting knobs have numbers so that the display message can be related to a specific fold roller.

The NOM and ACT values of the individual fold rollers can be displayed by pressing keys F1, F2 or F4.

Key F1 (+): Display of NOM and ACT value for the next roller (for example, advance from roller 2 to 3)

Key F2 (-): Display of NOM and ACT value for the previous roller (for example, return from roller 2 to 1)

Key F4 (AUTO+): Automatic advance of NOM and ACT to the fold roller, for which NOM and ACT do not agree

Description of the display messages:

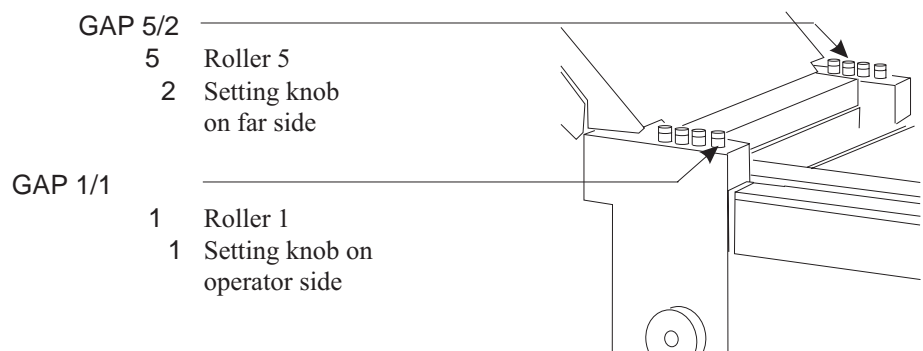

11. Press key F4 The fold plate stops and deflectors are positioned.

JOB SAVED:		9999
FORMAT (mm):	LENGTH:	WIDTH:
	420	297
FOLD IN FOLD UNIT	1: \angle	2: \angle
SETTING FOLD STYLE		
----- SELECT -----		FOLD SET-UP
JOB	CONTENTS	

F1

F3

F4

The line SETTING FOLD STYLE is flashing during set-up.

When the set-up is completed, this is signalled by a change of display:

SET-UP SELECT WITH FUNCTION KEYS		
SUCTION LENGTH →		F7
JOB SAVED →		F6
----- FOLD -----		
SPECIAL	STANDARD	ROLLER GAP
		DELI- VERY

F1

F2

F4

F5

12. Press key C Back to BASIC menu.

Displaying the Contents of Memory

1. Press key C The BASIC menu is displayed.

TOTAL: 00000000	JOB NO: 0000
OUTPUT: 00000 /h	MONITORING:
REMAINDER: 0000	DOUBLES: ON
	TRANSPORT: ON
MONITORING SAVING	
COUNTER	SET-UP JOB

F1 F2 F3 F4 F5

To recall a job from memory, the menu SET-UP must be called up by pressing key F3.

2. Press key F3 The SET-UP menu is displayed.

SET-UP SELECT WITH FUNCTION KEYS		
SUCTION LENGTH →		F7
JOB SAVED →		F6
----- FOLD -----		
SPECIAL	STANDARD	
ROLLER GAP	DELI- VERY	

F1 F2 F4 F5

3. Press key F6 The JOB SAVED menu is displayed.

JOB SAVED:		1111
FORMAT (mm):	LENGTH:	WIDTH:
	111	111
FOLD IN FOLD UNIT	1: \angle	2: \sphericalangle
AFTER ENTERING NUMBER: \leftarrow		
----- SELECT -----		FOLD SET-UP
JOB	CONTENTS	

F1

F3

F4

4. Press key F1

By pressing key F1 (JOB) several times, the memory number, the format and the fold type of each individual job are displayed, in the sequence in which the jobs were saved.

JOB SAVED:		3333
FORMAT (mm):	LENGTH:	WIDTH:
	333	333
FOLD IN FOLD UNIT	1: \angle	2: \sphericalangle
AFTER ENTERING NUMBER: \leftarrow		
----- SELECT -----		FOLD SET-UP
JOB	CONTENTS	

F1

F3

F4

Once the job is found, it can be set up as follows:

5. Enter the identification number Example: 9999

The length and width still refer to the previous job.



JOB SAVED:		9999
FORMAT (mm):	LENGTH:	WIDTH:
	111	111
FOLD IN FOLD UNIT	1: \angle	2: \sphericalangle
AFTER ENTERING NUMBER: \leftarrow		
----- SELECT -----		FOLD SET-UP
JOB	CONTENTS	

F1

F3

F4

6. Press key 

JOB SAVED:		9999
FORMAT (mm):	LENGTH:	WIDTH:
	420	297
FOLD IN FOLD UNIT	1: 	2: 
----- SELECT -----		FOLD SET-UP
JOB	CONTENTS	

F1
F3
F4

7. Press key F3 The CONTENTS menu is displayed.

JOB SAVED:		9999
DELIVERY	SPEED	SHEET GAP
07	08	06
MANUAL SETTING		
----- SELECT -----		FOLD SET-UP
JOB	CONTENTS	

F1
F3
F4

8. These figures must be entered manually by turning the knobs with the corresponding controls.

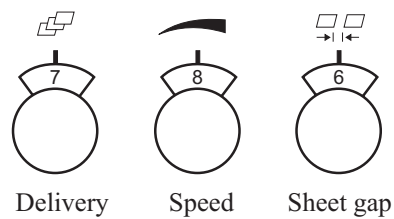

11. Press key F4 The fold plate stops and deflectors are positioned.

JOB SAVED:		9999
FORMAT (mm):	LENGTH:	WIDTH:
	420	297
FOLD IN FOLD UNIT	1: \angle	2: \sphericalangle
SETTING FOLD STYLE		
----- SELECT -----		FOLD SET-UP
JOB	CONTENTS	

F1

F3

F4

The line SETTING FOLD STYLE is flashing during set-up.

When the set-up is completed, this is signalled by a change of display:

SET-UP SELECT WITH FUNCTION KEYS			
SUCTION LENGTH →			F7
JOB SAVED →			F6
----- FOLD -----			
SPECIAL	STANDARD	ROLLER GAP	DELI- VERY

F1

F2

F4

F5

12. Press key C Back to BASIC menu.

2. Press key F3 The SET-UP menu is displayed.

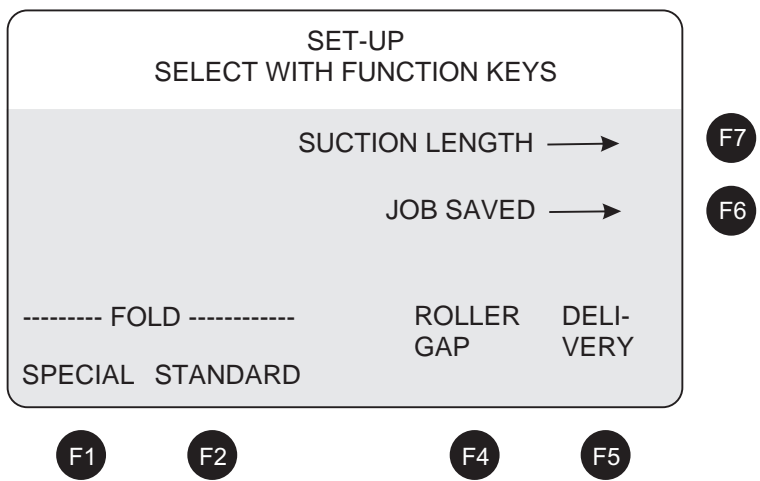

3. Press key F7 The suction length is displayed.

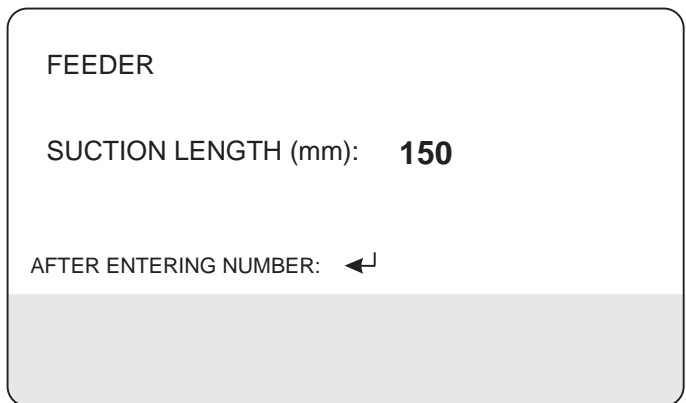

4. Enter suction length (90) The new suction length is displayed.

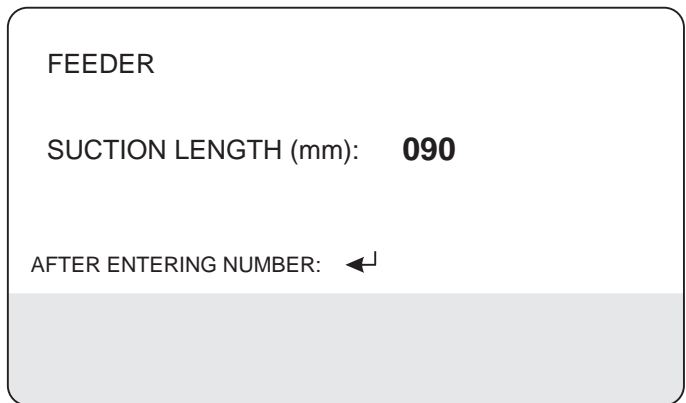

5. Press key ↵

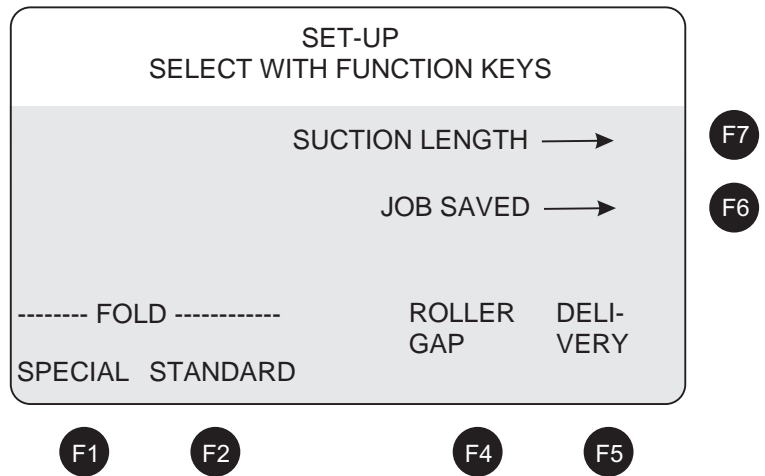

If further adjustment is needed after running some sample sheets, this can be done by pressing key F7 again.

When the job is saved, the information about the individually modified suction length is also saved.

During the next set-up process the modified suction length is set automatically.

Saving of Job Data - Main Menu SAVING

There is memory space for 60 individual fold jobs. A 4-digit identification number makes it possible to find each job anytime later.



The job cannot be saved before all settings have been completed, i.e. when no further corrections are required for:

- Fold length
- Sheet gap
- Roller gap
- Speed
- Suction length
- Shingling

1. Press key C The BASIC menu is displayed.

TOTAL:		JOB NO:	
00000000		0000	
OUTPUT:		MONITORING:	
00000 /h		DOUBLES: ON	
REMAINDER:		TRANSPORT: ON	
0000			
MONITORING		SAVING	
COUNTER	SET-UP	JOB	

F1
F2
F3
F4
F5

2. Press key F4 The SAVE JOB menu is displayed.

SAVE JOB

NUMBER OF ALREADY SAVED

JOB NO: **11** MAXIMUM: **60**

JOB NO: **0000**

AFTER ENTERING NUMBER: ←

F3



The display DATA INPUT only comes on when the job has been set up via the menu SPECIAL FOLDS.

When setting up via STANDARD FOLDS or JOB SAVED, the display DATA INPUT does not come on - type of fold and format have already been recognized. In these cases, continue with entering the job number (item 12).

3. Press key F3

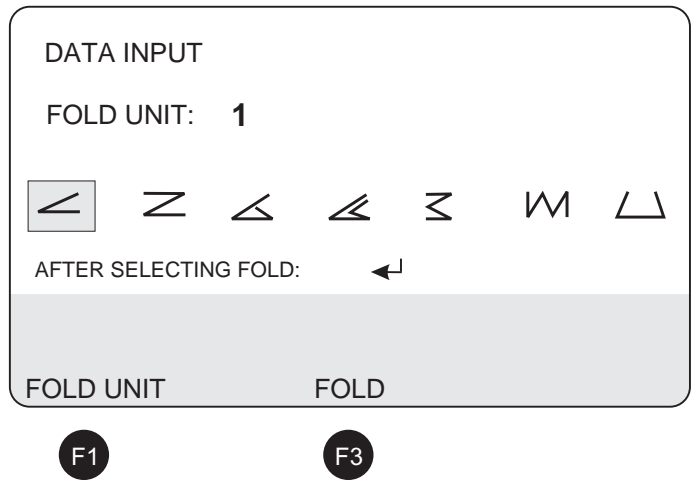

Since in our example a Z-fold was set up in the first fold unit, the cursor must be moved to the respective fold symbol.

4. Press key F3 until the respective fold symbol for the first fold unit (Z-fold) is marked by the cursor (dark rectangle).

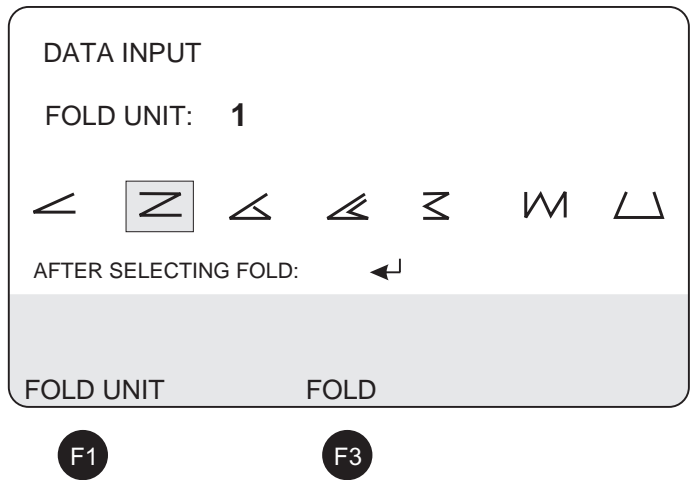

5. Press key ↵ The fold symbol is saved.

The format length of a previous job is shown in the display.

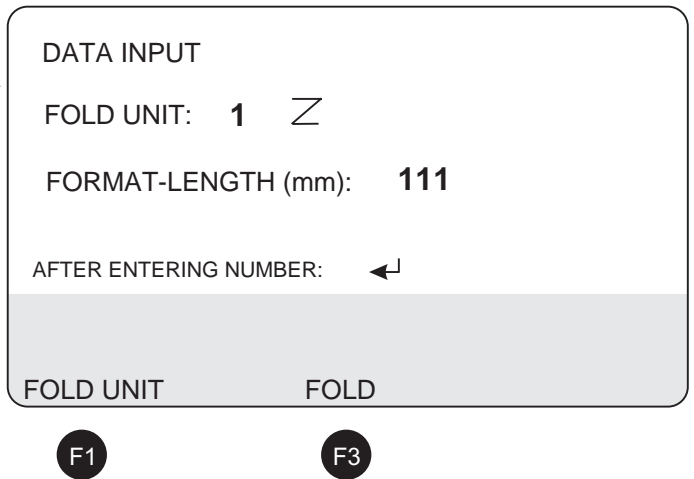

6. Enter the format length (420) The new format length is displayed.

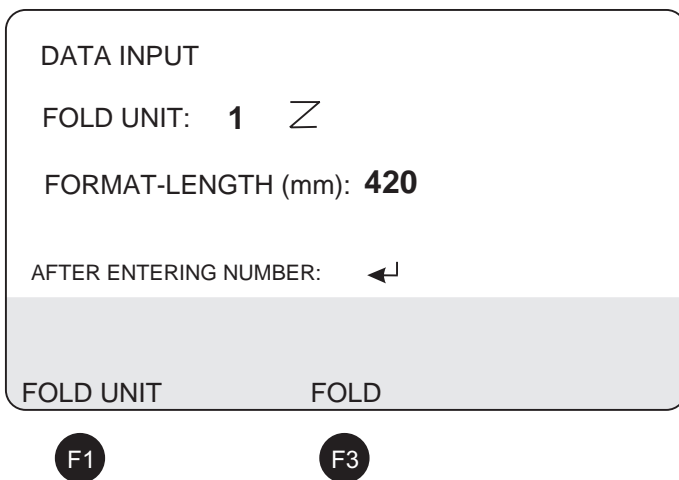

Enter the format length for job which has been set up (example: 420).

 If a format is entered that cannot be handled by the machine because it is too small or too large, this is recognized by the computer and shown in the display.

7. Press key ← The second fold unit is called up.

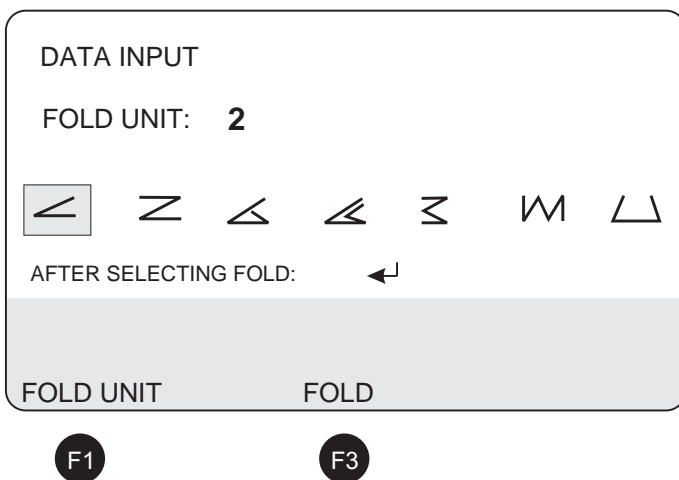

Since a letter fold was set up in the second fold unit, the cursor must be moved to the respective fold symbol.

7. Press key F3 repeatedly until the respective fold symbol for the second fold unit (letter fold) is marked by the cursor (dark rectangle).

DATA INPUT

FOLD UNIT: 2

AFTER SELECTING FOLD:

FOLD UNIT FOLD

F1 F3

9. Press key The fold symbol is saved.

The format width of a previous job is shown in the display.

DATA INPUT

FOLD UNIT: 1

FORMAT WIDTH (mm): 111

AFTER ENTERING NUMBER:

FOLD UNIT FOLD

F1 F3

10. Enter the format width (297) The new format width is displayed.

Enter the format width for the job which has been set up (example: 297).

DATA INPUT

FOLD UNIT: 1

FORMAT WIDTH (mm): 297

AFTER ENTERING NUMBER:

FOLD UNIT FOLD

F1 F3



If a format is entered that cannot be handled by the machine because it is too small or too large, this is recognized by the computer and shown in the display.

11. Press key ↵

SAVE JOB
NUMBER OF ALREADY SAVED
JOBS: **11** MAXIMUM: **60**
JOB NO: **0000**
AFTER ENTERING NUMBER: ↵

12. Enter the identification number (e.g. 9999)

SAVE JOB
NUMBER OF ALREADY SAVED
JOBS: **11** MAXIMUM: **60**
JOB NO: **9999**
AFTER ENTERING NUMBER: ↵

13. Press key ↵

If the selected memory space is already occupied, the display will ask whether it should be overwritten.

SAVE JOB
NUMBER OF ALREADY SAVED
JOBS: **11** MAXIMUM: **60**
JOB NO: **9999**
OVERWRITE? ↵

If the memory space is to be overwritten, proceed as follows:

14. Press key ↵

SAVE JOB
NUMBER OF ALREADY SAVED
JOBS: **11** MAXIMUM: **60**
JOB NO: **9999**
SAVING COMPLETED

15. Press key C

Back to BASIC menu.

Display of the Actual Job - Main Menu JOB

1. Press key C The BASIC menu is displayed.

TOTAL: 00000000	JOB NO: 0000
OUTPUT: 00000 /h	MONITORING:
REMAINDER: 0000	DOUBLES: ON
	TRANSPORT: ON
MONITORING SAVING	
COUNTER	SET-UP JOB

F1 F2 F3 F4 F5

2. Press key F5 Display of the actual job.





ACTUAL JOB:	1111	
FORMAT (mm)	LENGTH:	WIDTH:
	420	297
FOLD		
IN FOLD UNIT:	1: \angle	2: \angle



In this menu only the format and type of fold of the actual job are displayed. Settings cannot be made at this point.

Correction of Fold Lengths - Menu FOLD LENGTH

1. Press key  The FOLD LENGTH menu is displayed.

FOLD LENGTH (mm)				
FOLD UNIT:	1	PLATE:	1	
ACT:	207.0	NOM:		
CORRECT WITH +/-				
UNIT	PLATE	-	+	SET-UP
				

In this menu, all necessary corrections of the fold lengths of a set-up job can be made.

Key F1 will switch from the first to the second fold unit and vice versa.

Key F2 will display the fold lengths of all fold plates.

Key F3 will reduce the fold length in steps of 0.25 mm.

Key F4 will increase the fold length in steps of 0.25 mm.

Key F5 is inactive, because every correction is immediately transferred to each stop. Every change of 0.5 mm is displayed.

2. Press key C Back to BASIC menu.

Setting the Fold Rollers - Menu ROLLER GAP

The fold rollers are set on the basis of information from the computer control.
 The correct gap is calculated taking into account the selected type of fold and the paper weight and is then shown on the display.
 This setting value must be transferred to the left and right setting knobs (1) associated with each fold roller.

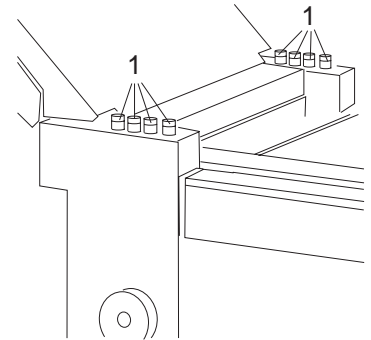

 Before setting the fold rollers the fold lengths in all fold plates must already be set.

1. Press key C The BASIC menu is displayed.

TOTAL: 0000000		JOB NO: 0000	
OUTPUT: 00000 /h		MONITORING: ON	
REMAINDER: 0000		DOUBLES: ON	
		TRANSPORT: ON	
MONITORING		SAVING	
COUNTER	SET-UP	JOB	

F1
F2
F3
F4
F5

2. Press key F3 The SET-UP menu is displayed.

SET-UP
SELECT WITH FUNCTION KEYS

SUCTION LENGTH → F7

JOB SAVED → F6

----- FOLD -----

SPECIAL STANDARD ROLLER GAP DELI-VERY

F1
F2
F4
F5

3. Press key F4 The ROLLER GAP menu is displayed.

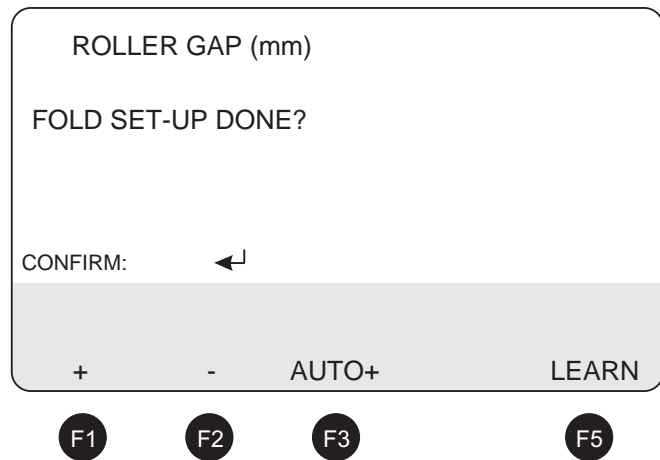

4. Press key ←

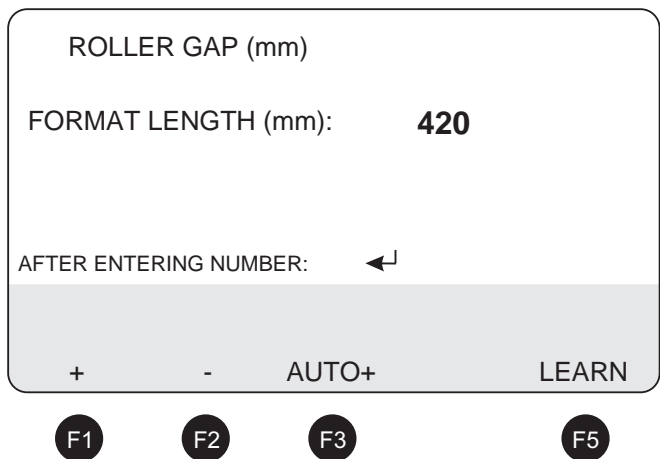

5. Press key ←

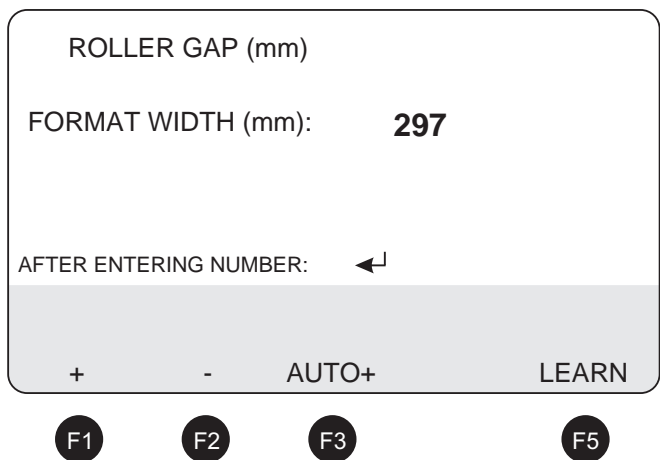

6. Press key 

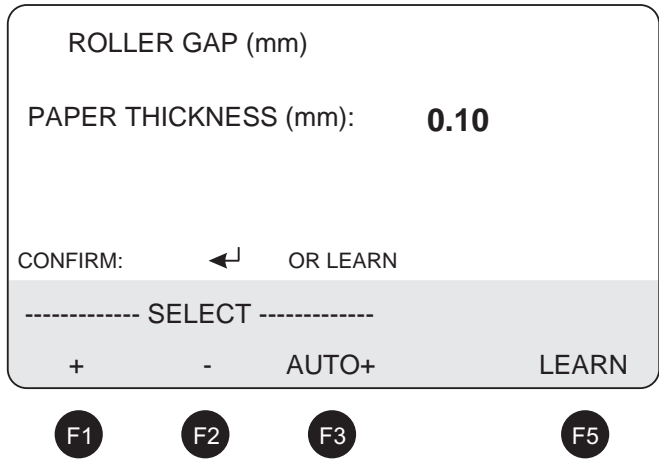

7. Press key 

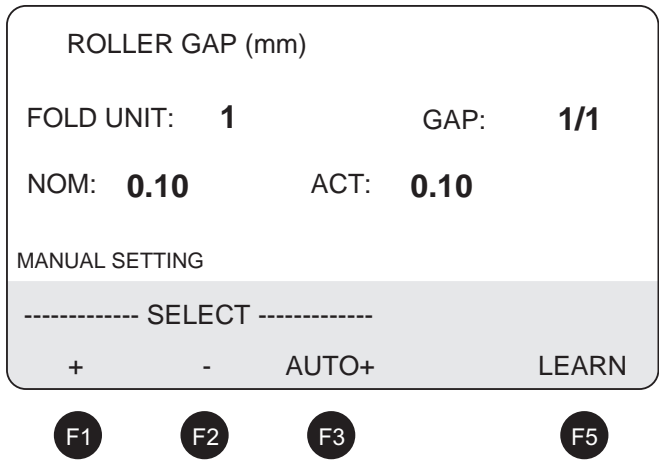

 The **NOM**inal value shown is the calculated value resulting from paper thickness and fold type.

For correct setting of the fold rollers the **ACT** (Actual) value must be changed to the **NOM** (Nominal) value. This is done by turning the setting knobs (1). All setting knobs have numbers so that the display message can be related to a specific fold roller.

The **NOM** and **ACT** values of the individual fold rollers can be displayed by pressing keys F1, F2 or F3.

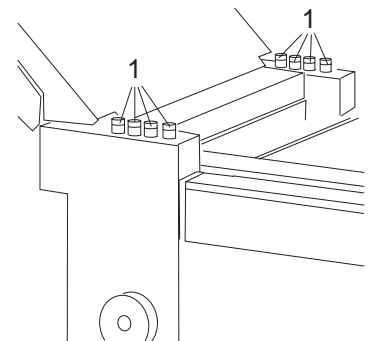

Key F1 (+): Display of **NOM** and **ACT** value for the next roller
(for example, advance from roller 2 to 3)

Key F2 (-): Display of **NOM** and **ACT** value for the previous roller
(for example, return from roller 2 to 1)

Key F3 (AUTO+): Automatic advance of **NOM** and **ACT** to the fold roller,
for which **NOM** and **ACT** do not agree

Description of the display messages:

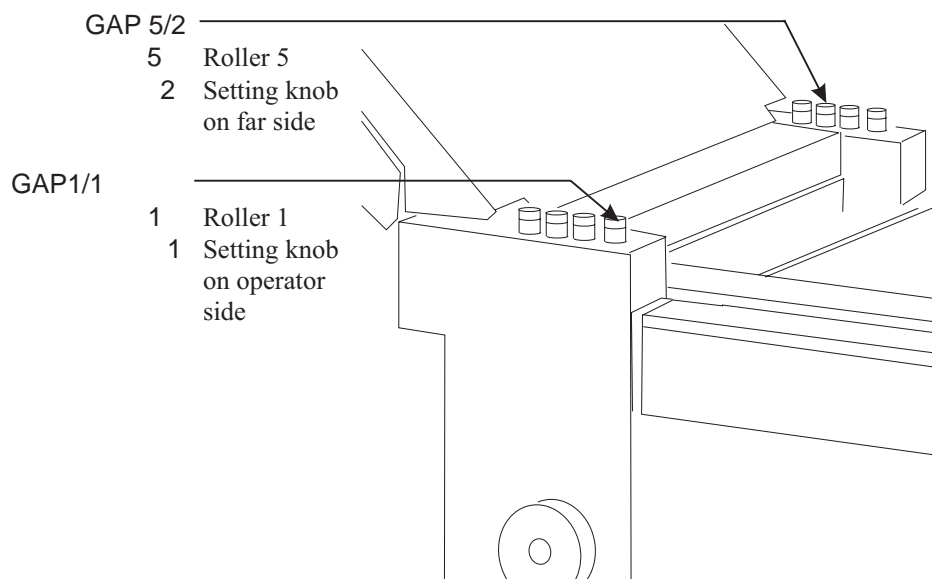

- 8.** Turn setting knob 1 (operator side) on the first fold unit until ACT shows the same value as NOM.

Repeat this procedure until all fold rollers are set.

- 9.** Press key C Back to BASIC menu.

Individual Corrections

When trial folds show that the setting of the fold rollers should be improved, an individual correction is possible.

- 1.** Press key F8 Menu ROLLER GAP is displayed.

ROLLER GAP (mm)

FOLD UNIT: **1** GAP: **1/1**

NOM: **0.10** ACT: **0.10**

MANUAL SETTING ←

----- SELECT -----

+ - AUTO+ LEARN

F1
 F2
 F3
 F5

- 2.** Correct the roller gap by means of the setting screws

ROLLER GAP (mm)

FOLD UNIT: **1** GAP: **1/1**

NOM: **0.10** ACT: **0.15**

MANUAL SETTING ←

----- SELECT -----

+ - AUTO+ LEARN

F1
 F2
 F3
 F5

This means that individual corrections are possible for all roller gaps. For repetitive jobs stored in the memory the corrected value will then be shown as NOMINAL value.

- 3.** Press key C Back to BASIC menu.

Setting the Delivery Rollers - Menu DELIVERY

1. Press key C The BASIC menu is displayed.

TOTAL: 0000000	JOB NO: 0000
OUTPUT: 00000 /h	MONITORING: DOUBLES: ON TRANSPORT: ON
REMAINDER: 0000	
MONITORING SAVING	
COUNTER	SET-UP JOB

F1 F2 F3 F4 F5

2. Press key F3 The SET-UP menu is displayed.

SET-UP SELECT WITH FUNCTION KEYS				
			SUCTION LENGTH →	F7
			JOB SAVED →	F6
—— FOLD ——				
SPECIAL	STANDARD	ROLLER GAP	DELI- VERY	

F1 F2 F4 F5

3. Press key F5 The DELIVERY menu is displayed.

DELIVERY ROLLER POSITION (cm)	
FOLD SET-UP DONE ?	
CONFIRM:	←

4. Press key ↵

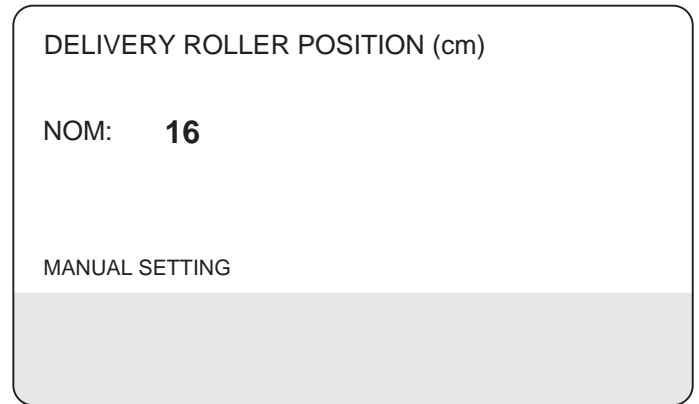

5. Set the delivery rollers to the format by using the scale.

6. Press key C Back to BASIC menu.

Choosing the Measuring System and the Language

1. Press key F9 The following display appears:

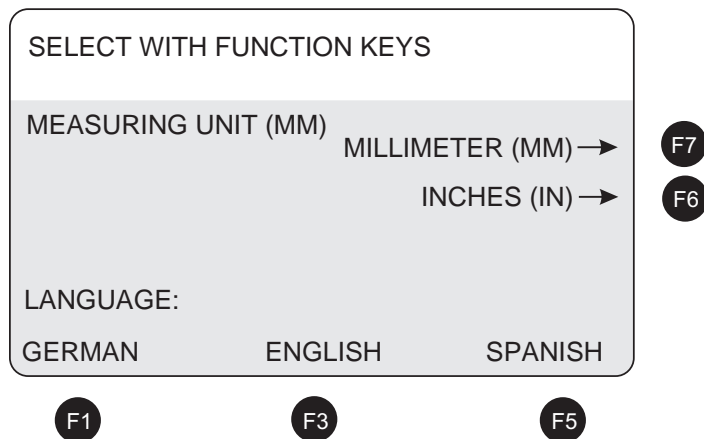

Use key F7 to switch from Inches to Metric.

Use key F6 to switch from Metric to Inches.

Press keys F1, F3 or F5 to choose a language.

2. Press key C Back to BASIC menu.

Fold Plate Setting: Three Methods

In the previous chapters we have described the different menus and their possibilities. It is, however, up to you to choose the menu for setting up a fold job.

The diagram that you find below shows the three possible ways which all produce the same result.

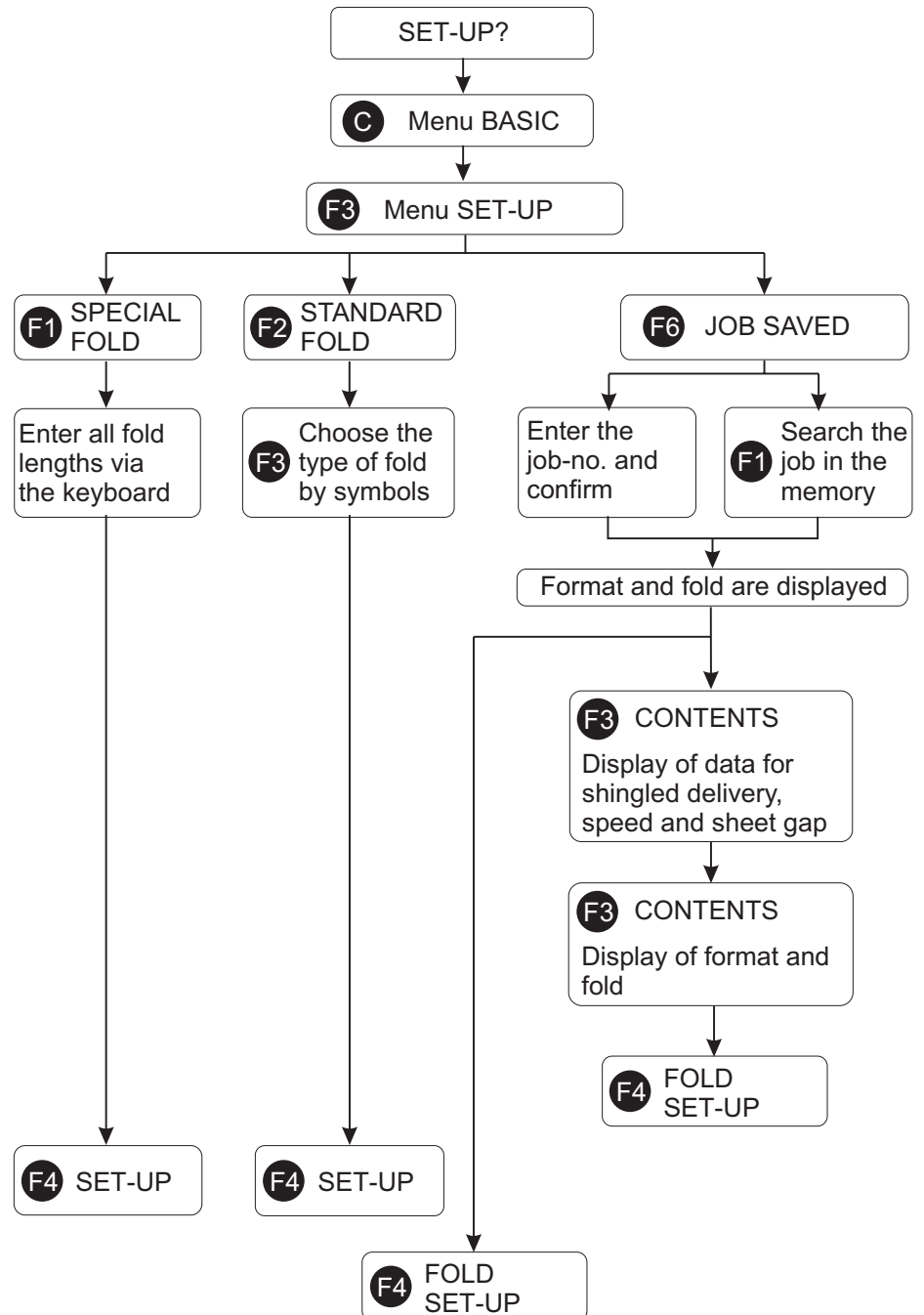

Roller Gap: Three Methods

Calling up the data for the roller gap must always be done from the main menu SET-UP.

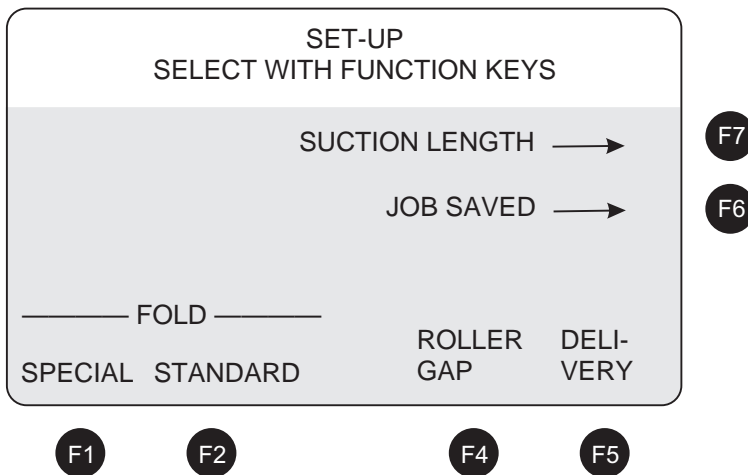

1. Calling up the menu ROLLER GAP by pressing key F4.

This should be done, when

- the set-up was made by entering the fold lengths (special fold)
- the set-up was triggered by marking the fold symbols (standard folds)

2. Calling up the menu JOB SAVED by pressing key F6.

This applies when

- the set-up is to be made by recalling a job from the memory



If a different paper is used for the job recalled from the memory, the data shown in the display cannot be used.

In this case the roller gap must be set via the menu ROLLER GAP.

3. Calling up the menu ROLLER GAP by pressing key F4.

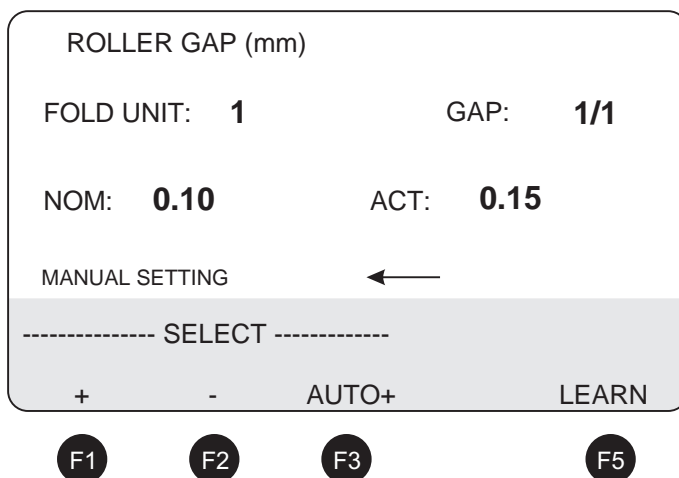

In this menu, the roller gap setting can be corrected and displayed.

Different Possibilities for Displaying the Roller Gap:

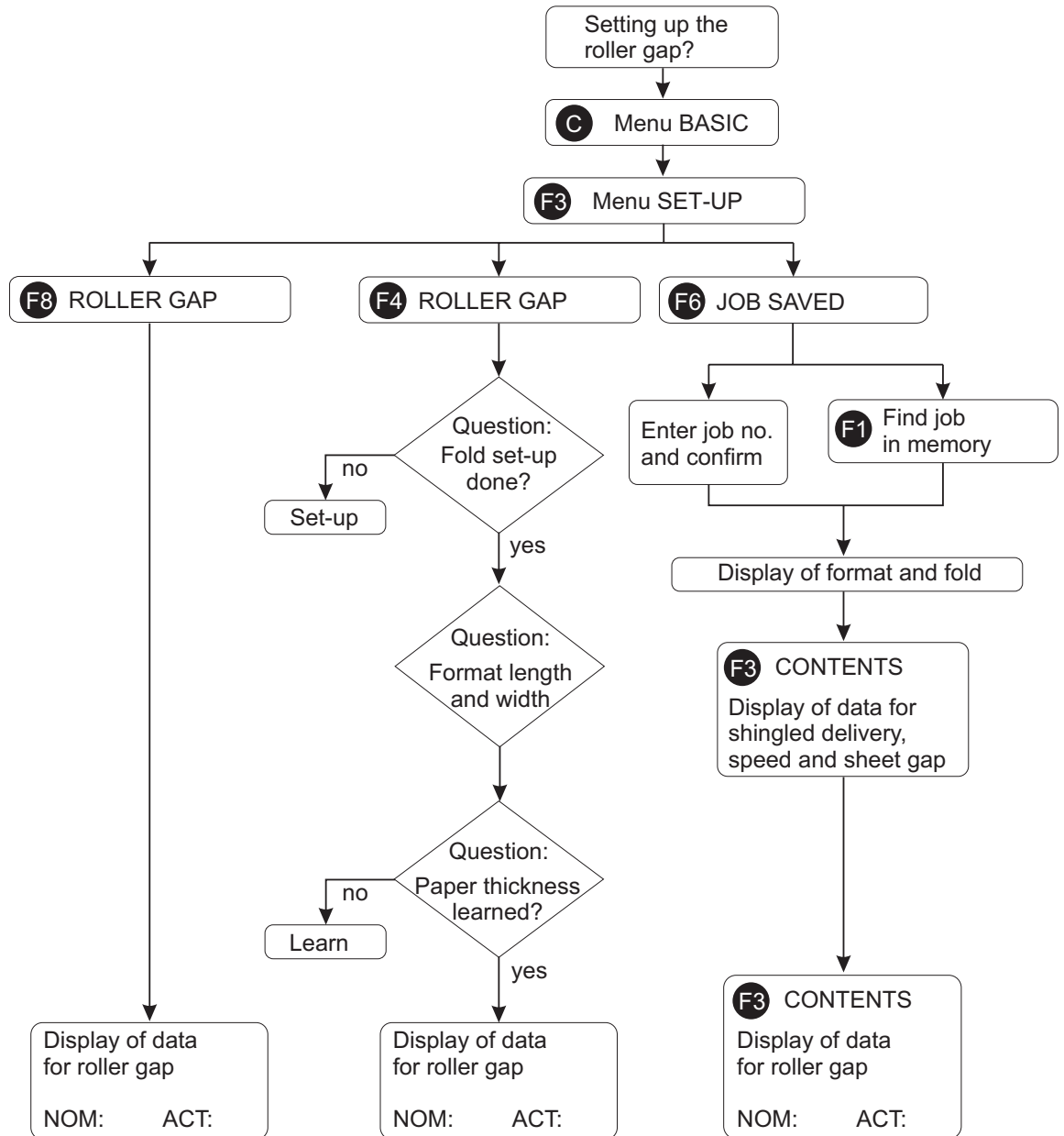

Display of Malfunctions

The machine is equipped with an operator-convenient malfunction detection system. If malfunctions occur, they are identified by different sensors and the machine is stopped.

The display gives information on

1. Location of malfunction
2. Cause of malfunction
3. Measures to clear the malfunction

Examples for the identification of malfunctions:

ERROR SHEET GAP
WHEN FEEDING FROM FEEDER

→ INCREASE SHEET GAP
OR IMPROVE SHEET TRANSPORT
ON REGISTER TABLE

CONTINUE WITH KEY C

ERROR
SHEET TRANSPORT IN FOLD UNIT II

AT LEAST ONE SHEET WAS DELAYED

→ REMOVE CAUSE

CONTINUE WITH KEY C

ERROR
PHOTODETECTOR IN INFEED SECTION
FOLD UNIT I IS COVERED

→ REMOVE CAUSE

CONTINUE WITH KEY C

ERROR DOUBLE SHEET

→ REMOVE DOUBLE SHEET

CONTINUE WITH KEY C

STANDARD FOLDS

FOLD UNIT: **2**

WRONG ENTRY

MINIMUM: MAXIMUM:

ERROR FOLD UNIT 1

PAPER JAM → CHECK

DRIVE OR ENCODER

CONTINUE WITH KEY C

Check whether a paper jam has occurred. If this is not the case, the malfunction may have been caused by an error in the drive or the encoder.

If the motor starts briefly and the error display comes on again, the drive is working correctly. This means that the reason is a defect in the encoder.

If the motor does not start at all, the drive is defective.



Call a service technician.

Service Functions

The service menu can be called up by pressing key F12. It is primarily used by the service technician.

1. Press key F12 The SERVICE menu is displayed.

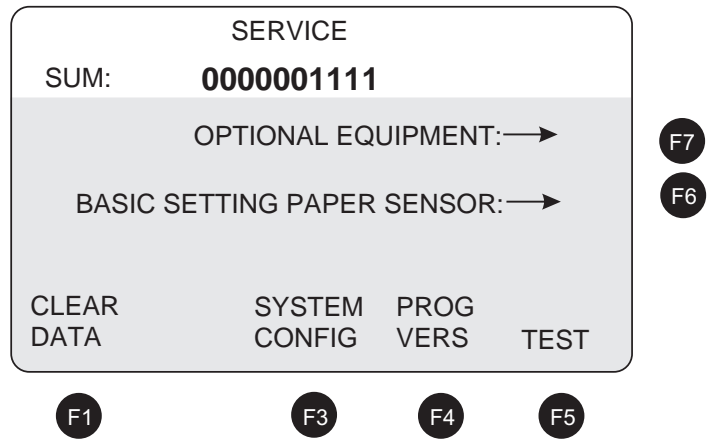

Data (F1) can only be erased by a service technician, this is why a special code number is needed.

By pressing key F5, information about shingling, speed, gap, etc. can be shown in the display.

Pressing key F4 will show the program version.

By pressing key F3, a menu is called up where machine configurations can be changed. This is necessary if, for instance, the folder is equipped with a different feeder or a second fold unit.

2. Press key F3



To prevent accidentally changing the machine configuration, a code number must be entered here. This code number is 4250.

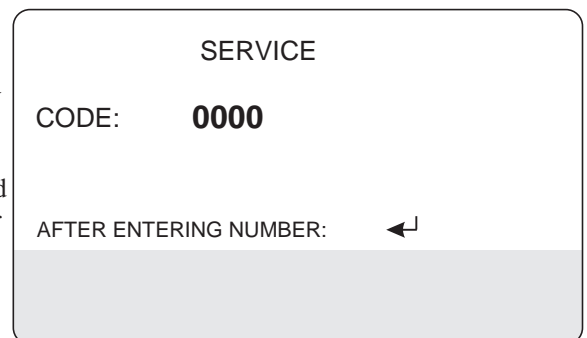

3. Enter the code number

4250

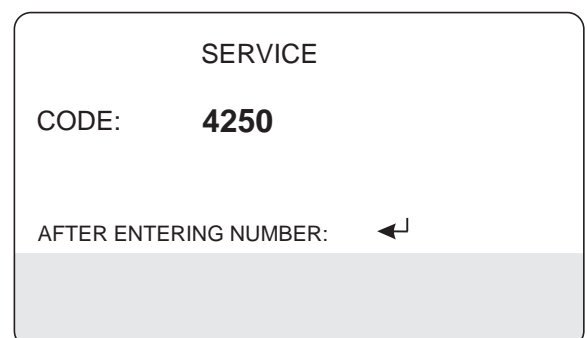

4. Press key ↵

CONFIGURATION

NUMBER OF PLATES IN
FOLD UNIT 2: 4

2 4 SELECT

F1 F2 F5



Confirm whether the fold unit is equipped with 2 or 4 fold plates by pressing keys F1 or F2.

5. Press key F5

CONFIGURATION

FEEDER:
FLAT PILE FEEDER

FPF PSF EXT. SELECT

F1 F2 F3 F5

The type of feeder can be chosen by pressing keys F1 to F3.

6. Press key C**Back to BASIC menu.**

The service menu can also be used to check the basic setting of the paper thickness sensor.

1. Press key F12 The SERVICE menu is displayed.

2. Press key F6

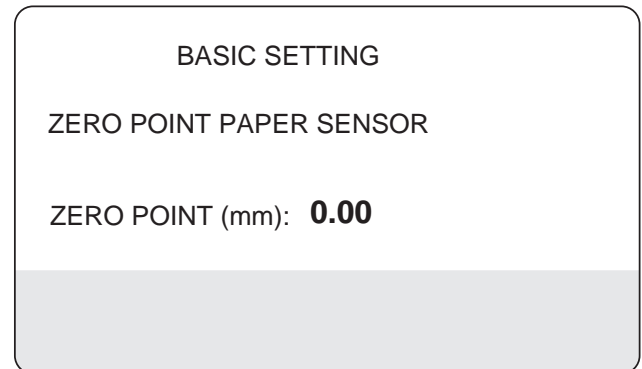

The zero point of the paper thickness sensor is adjusted by the service technician when first installing the machine.

It is possible that the value changes slightly in the course of time, for example because the ambient temperature is not constant.

This has no influence on the function.



If, however, values above +0.30 or below -0.09 are displayed, the sensor must be readjusted. The instructions are part of the machine documentation that can be found in the control box.

This is indicated on the display when the double sheet detection is being activated.

3. Press key C Back to BASIC menu.

17. OPERATION AND TRIAL FOLDS

After all adjustments have been completed for a particular job, check the result by making a few trial folds.



**Exercise caution in the vicinity of rotating shafts and rollers!
Hair, loose garments and jewellery may get caught!
SERIOUS INJURY MAY RESULT!**



**Exercise caution when running the machine with safety covers open and fold plates removed! Do not get close to the rotating fold rollers!
SERIOUS INJURY MAY RESULT!**



When making or breaking any electrical connection, always first turn off the main switch or the safety switch on the folder. Non-compliance may cause damage to electronic components!



Exercise caution at the delivery end of the fold unit! Do not get close to the rotating delivery shafts! SERIOUS INJURY MAY RESULT!

The operating sequence is as follows:

Place paper on the feed table.



Press key C or switch on main switch.



Set the **sheet gap in the delivery section** to the medium position by turning this knob.



If the kicker is used, this knob will set the trigger point for the kicker.



Set the **folding speed** to the medium position by turning this knob.



Set the **sheet gap on the register table** to the medium position by turning this knob.



Switch on the **pump** by touching this key.



Switch on the **main motor** by touching this key.







Activate **sheet feed** by touching this key:

Brief touch:

Single sheet

Touching key for approx. 2 sec.:

Continuous feed

-  Switch off the machine in reverse order:
-  Sheet feed
-  Main motor
-  Pump

18. FINE ADJUSTMENTS AND CORRECTIONS

Speed of the 2nd Fold Unit

Normally it is not necessary to adjust the speed of the first and second fold unit separately. Settings are automatically transferred to both fold units. If, however, the speed of the second fold unit must be changed separately because of the paper size and the type of fold, there is a potentiometer in the base of the second fold unit which can be adjusted by means of a screwdriver.

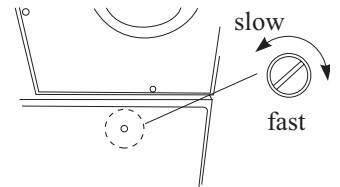

Fold Lengths

Fold variations may occur if the fold plate stops are not set accurately or if the folding speed is changed. The fold is off across the entire width of the sheets.

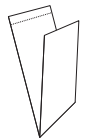

Press key  and make the fine adjustment via the menu FOLD LENGTH.



A change in the folding speed also changes the fold length. Therefore the set-up speed must be maintained.

Skewed Folds

Skewed (out-of-square) folds occur when the paper is not fed at right angles with respect to the fold rollers. This can be corrected as follows:

- Mark the leading edge of a sheet and feed it through the folder (1).

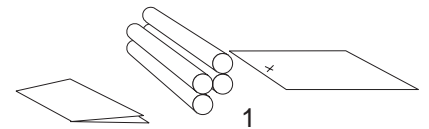

- To make the deviation more obvious, exaggerate the skewed fold by hand (2).

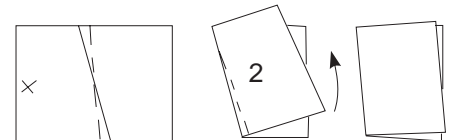

- Open the folded sheet and place it in front of the roller infeed section (3).

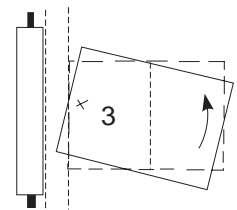

- By turning the adjustment wheel on the register table (4) resp. on the roller table (5), the register rail must be adjusted in such a way that the leading edge of the paper is parallel to the fold rollers.

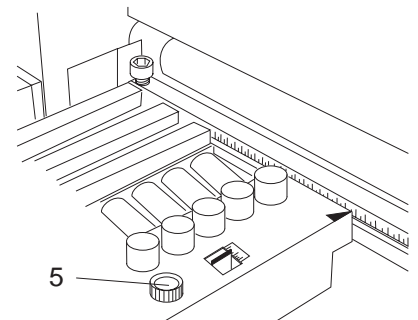
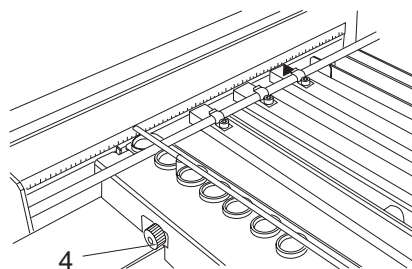

Out-of-Square Paper

If the paper is not cut precisely at right angles, the folded sheet may show "points". By turning a setting knob, the fold plate stop can be made parallel to the out-of-square leading edge of the paper.

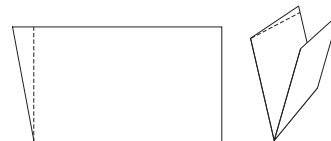

Make this correction only on the first fold plate.

It is possible to change the parallelism of the stop by turning the knurled knob (1).

- Loosen the knurled knob by means of a 4 mm Allen key (2). The angle of the stop is changed by turning the two knurled knobs. The stop is parallel to the fold rollers when the two half-round marks (3) face each other.

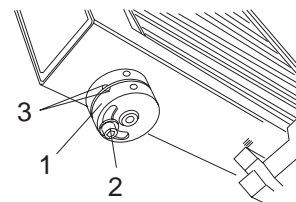

Shadow Fold

The lower lip can be adjusted by means of a setting knob (4)

Basic position:
The wide groove is flush with the top of the knob.

Lower lip advanced:
Small buckle space.

Lower lip set back:
Large buckle space.

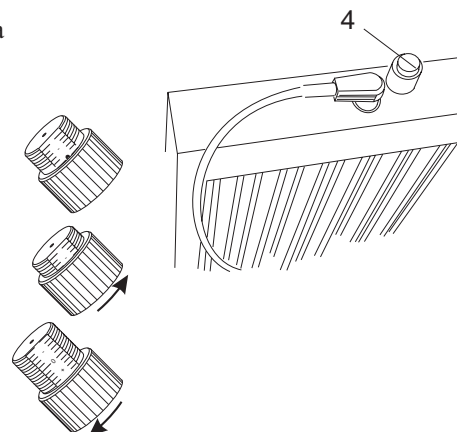

- Thin paper grades: Advance the lower lip by turning the knob counter-clockwise.
- Heavy paper grades: Set back the lower lip by turning the knob clockwise.

Accordion Fold

It is possible that heavy paper grades get stuck and form a so-called "accordion fold". In such a case the fold plates must be set back.

- Loosen the Allen screws (5) on both sides of the fold plate.
- Set back the fold plate by using the scale (6).
- Tighten the Allen screws.
- Change the fold plate stop by the same amount.

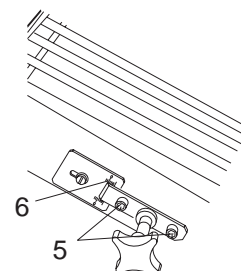

Creasing

When special types of paper are folded, deviations from the calculated and displayed NOMINAL values may become necessary.

Individual corrections can be made by means of the numbered setting knobs at each roller.

The fold rollers and delivery shafts with the matching setting knobs are arranged according to the following scheme:

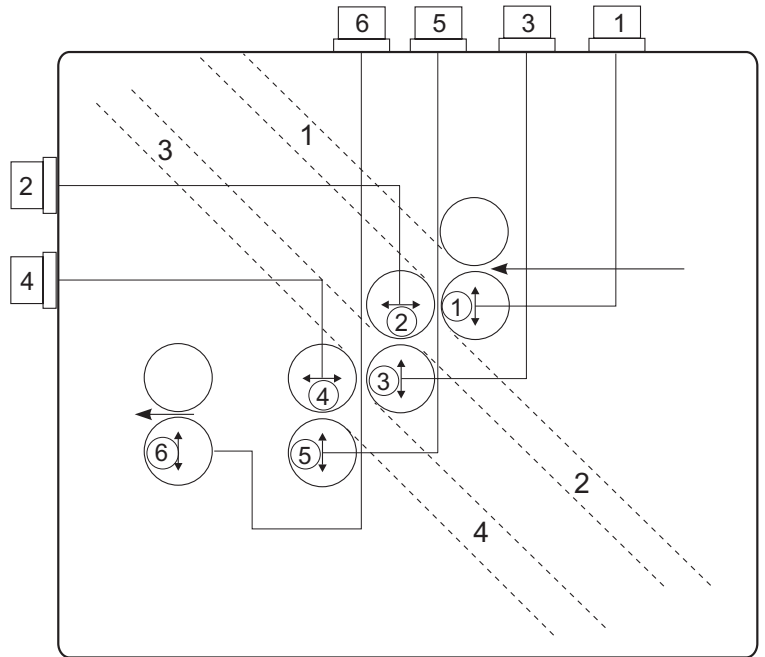

The layout sketch shows a fold unit with 4 fold plates.



There are no fold rollers 4 and 5 in a fold unit with 2 fold plates.
The delivery shaft has the number 4.

The number on the setting knob corresponds with the fold plate bearing the same number.

Roller 1	is the	feed roller
Roller 2	makes the	1st fold
Roller 3	makes the	2nd fold
Roller 4	makes the	3rd fold
Roller 5	makes the	4th fold
Roller 6	is the	delivery shaft



The setting knobs are equipped with scales (1).
With their help settings with a precision of 0.01 mm are possible.

An additional scale (2) indicates adjustments in steps of 0.5 mm.

To increase the roller gap, turn the setting knob counter-clockwise.

To reduce the roller gap, turn the setting knob clockwise.

When the roller gap is changed by more than 0.5 mm, the values on both scales must be added.

Example: 0,5 (2) + 16 (1) = 0,66 mm

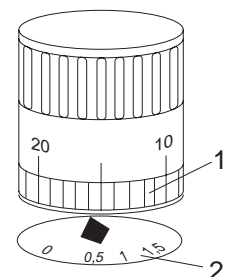

19. Perforating-, Scoring- and Slitting Tools



Perforating- and slitting knives have sharp edges for proper function! Exercise caution when removing and installing them! SERIOUS INJURY MAY RESULT!



Before installing or removing perforating-, scoring- or slitting tools, always PULL the power plug. This will ensure that no other person will be able to start the machine while you are working on it.

Various perforating-, scoring- and slitting tools are available. Their usage is determined by the type of paper and the kind of perforating-, scoring- or slitting job.

All perforating-, scoring- or slitting tools consist of an upper and a lower part. The upper part is positioned on the upper delivery shaft, the lower part on the lower delivery shaft.

Perforating Tools

Purpose of perforating: To avoid creasing when making crossfolds.
Air can escape from the folded sheet through the perforations.

Perforating (1) is done by the serrated perforating knife (2) and the straight-edge lower knife (3).

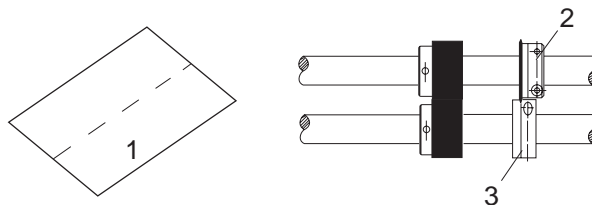

Various perforating knives are available which differ in the type and number of teeth. Their usage is determined by the type of paper and the kind of perforating job.

 Light paper grades: short cuts, many teeth
Heavy paper grades: long cuts, few teeth

The perforating knife is normally mounted on the upper delivery shaft and its counterpart on the lower shaft.

Knives for push-through perforation are always mounted on the upper shaft.

 When perforating and slitting light stock the paper may stick to the knife. A stripper is used to prevent this. The stripper should be mounted as close as possible to the perforating knife.

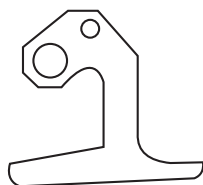

Paper stripper for upper perforating knife

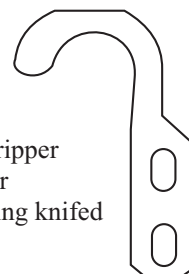

Paper stripper for lower perforating knife



Waste stripper for cut-out

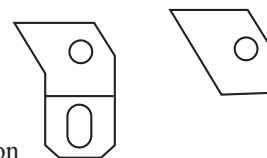

Waste stripper for ridgeless perforation



When setting the strippers, take care that they do not touch the delivery shaft!



If the sheets are only perforated and not folded, the telescopic hold-downs (4) should be used to support paper transport on the delivery table.

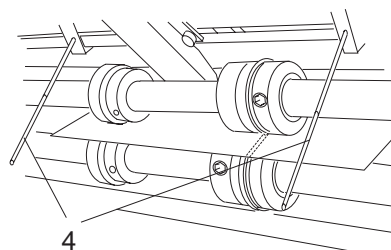

Scoring Tools

Purpose of scoring: To create a hinge-type zone to aid the subsequent crossfold:

- if the sheet cannot be perforated for functional reasons
- if stiff or coated papers are handled
- if the grain of paper is going the wrong way

Scoring (1) is done with a male scoring wheel (2) and a female counterpart (3). A groove is pressed into the paper when it passes between the tools. The texture of the material remains intact.

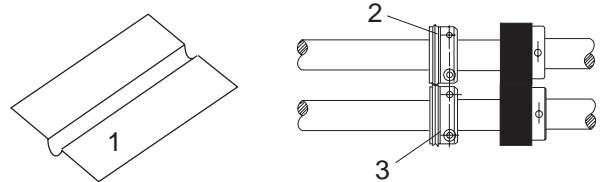

Scoring wheels with different widths are available for scoring, depending on the paper thickness.

 Thin paper: narrow scoring wheel
 Heavy paper: wide scoring wheel

The male scoring wheel can be attached on the upper or lower ejector shaft, depending on the subsequent type of fold.

 Upper ejector shaft: subsequent fold in fold plate 1 or 3
 Lower ejector shaft: subsequent fold in fold plate 2 or 4

Slitting Tools

Purpose of slitting: Slitting, trimming and strip cutting.

An upper (5) and a lower (6) knife are required for slitting (4).

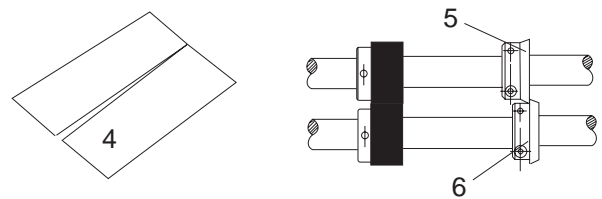

The lower knife must be positioned close to the upper knife.

Installation of Perforating-, Scoring- or Slitting Knives

If a transfer bridge is attached to the fold unit, remove it first. Proceed as follows:

- Slide the two drive belts off the pulleys (1).
- Remove the screws on the left- and right-hand side (2).
- Take out the transfer bridge with both hands.
- Remove the delivery shafts before installing the tools.
First remove the upper (3), then the lower (4) delivery shaft.
- Loosen the Allen screws (5) (5-mm-key) on the left- and right-hand side of the delivery roller sleeves (6).
- Hold the delivery shaft with one hand and slide the delivery shaft sleeve towards the center (7) with the other hand.
Take out the delivery shaft.



If it does not come off easily, rock it slightly back and forth (up to $\frac{1}{4}$ turn).

- Loosen the delivery rollers (8) which are located in front of the position intended for the tools, by means of a 3-mm Allen key and slide them off the delivery shaft.
- Mount the perforating-, scoring- or slitting tools on the delivery shafts.



Always install the tools on the **upper** delivery shaft in such a way that the lock screws are located on the **right** (on the left, as seen in direction of paper travel) of the scoring disk resp. the slitting- or perforating knife (9). On the **lower** delivery shaft the lock screw must be on the **left** (on the right, as seen in direction of paper travel) (10).



If this is not observed, a clamping collar of the tool may open caused by the rotation of the delivery shaft.

- After installing the tools, also replace the delivery rollers removed previously.

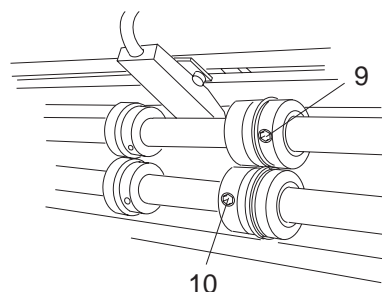
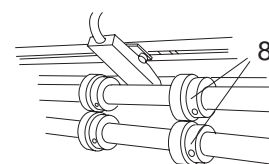
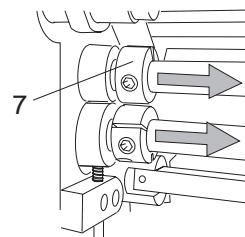
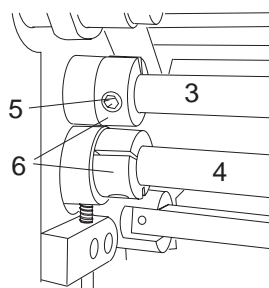
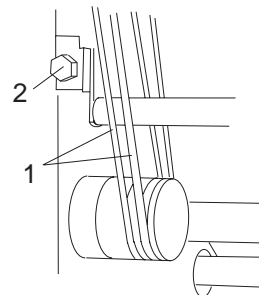

Re-install the delivery shafts.



First install the lower, then the upper delivery shaft.

Make sure that the upper and lower parts of the tools are not damaged.

- Insert the delivery shafts into the drive pins (1).
- Slide the delivery shaft sleeves (2) to the left and to the right over the drive pins.
- Insert the Allen screws into the delivery shaft sleeves by means of a 5-mm-key and tighten while pushing the delivery shaft sleeves outwards to keep the side play as small as possible.

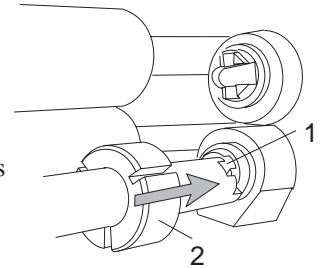

After the installation of the perforating-, scoring- or slitting tools re-install the transfer bridge if used.

- Attach the transfer bridge.
- Insert the screws (3) left and right by means of a 13 mm screw and tighten.
- Place the belts on the pulleys (4).

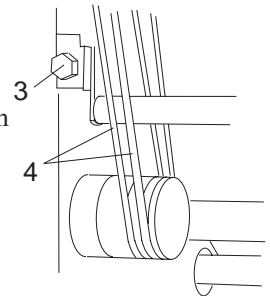

Positioning the Tools

- Loosen the Allen screws (1) so that the tools can be shifted on the delivery shafts.
- Run a sheet (2) through the fold unit by turning the handwheel.
- Slide the assembled tools (3) to the exact location on the delivery shaft.
- Secure the upper and lower tool by tightening the Allen screws.

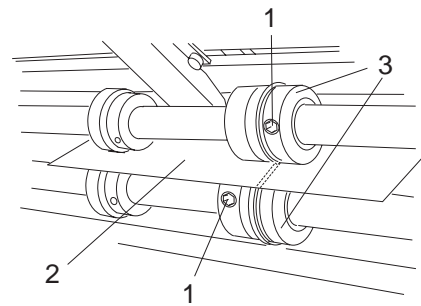

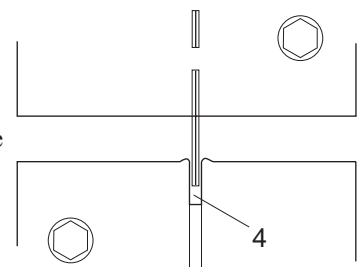

 Make sure that the tools on the upper and lower delivery shaft mate properly.

 Perforating knives and scoring disks which work against a groove in the mating part (4) must run exactly in the center of the groove. If the setting is not precise, the paper may be cut completely or the tools may wear prematurely.

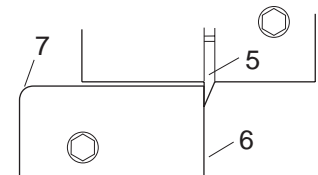

 Perforating and slitting knives (5) which work against a mating knife (6) (scissor action) must be positioned as close as possible.



 Do not use the rounded off edge of the lower slitting knife (7) for slitting or perforating.

When the tools are not needed, they can still remain on the delivery shafts. Just loosen the Allen screws and move them apart so that the upper and lower tool no longer touch each other (8).

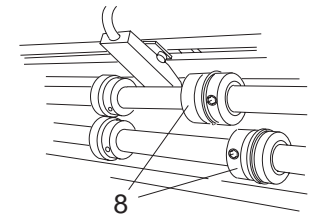

Travel Limit of the Lower Delivery Shaft

The lower delivery shaft is spring-loaded. The resulting travel of the delivery shaft can be adjusted by loosening and tightening two adjusting screws (9). In addition to setting the screws, two pressure springs (10) have been installed between the bearing arm and the stop. They serve as dampers for the lower delivery shaft.

 The travel should be as small as possible to achieve a precise scoring, perforation or a straight cut. The exact position of the two screws (9) can be determined by running a few sample sheets. When working without any perforating-, scoring- or slitting tool, screw both screws all the way out for maximum travel.

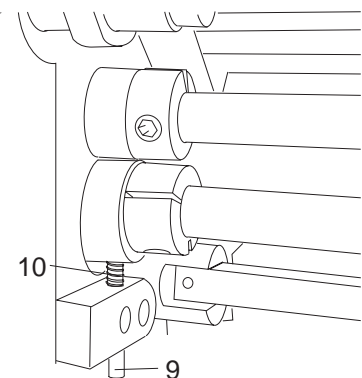

20. Possible Malfunctions and their Remedies

Take the following precautions before correcting a malfunction:



Only service technicians should deal with electrical and electronic components!



Before removing covers and other safety devices, pull the power plug and secure the machine against unauthorized or unintentional use (warning sign).

Error	see no.				
Paper lift mechanism of flat pile feeder does not work	1	2			
Pump does not start	3				
Malfunction in feed section	4	5	6		
Fold plate stops of fold plates 1 to 4 do not move SETTING FOLD STYLE remains in display	7	8	9	10	
Stops and deflectors of fold plates 1 to 4 remain in base position (no fold) although a fold length was entered - 0000 remains in display	11				
Paper stop of one fold plate cannot be moved to another position	7	12			
Standard folds cannot be set - SETTING FOLD STYLE remains in display	7	13			
Paper is not transported into fold plate	8	10	14	15	
Motor of fold roller drive cannot be started	16	17			
Display shows DOUBLE SHEET	18	19			
Sudden machine stop	20	21	22		
Belts on delivery table do not move	23	24			
Pump and main motor cannot be switched off via keyboard	25				
Suction drum does not move	26				
The red jam warning light at the flat pile feeder comes on	27				

No:	Possible Cause:	Remedy:
1	Thermal overload protection on feeder has switched off	Remove front cover of flat pile feeder (hexhead nut M13) and set thermal overload protection to a higher value
2	Round plug between feeder and register table not plugged correctly	Check connection
3	Thermal overload protection in electrical compartment has switched off	Open electrical compartment in fold unit 1 (pull out drawer), set thermal overload protection to higher value
4	Photodetector 1 covered with paper or dirty	Remove paper or clean photodetector
5	Sensibility of photodetector 1 too low	Change sensibility by turning potentiometer on photodetector: Red light in LED must come on when a sheet covers photodetector
6	Photodetector 1 defective	Replace photodetector 1
7	Fold plate plug not connected properly	Switch off main switch. Check plug of fold plates for proper fit
8	Deflector mechanism jammed	Move fork to its base position
9	Gear motor for adjustment of paper stop is defective	Replace gear motor
10	Deflector jammed, does not return to base position	Clean bearing point, check deflector for easy movement
11	Fold plate stop jammed Display shows: 0000	Remove fold plate. Loosen Allen screws (2.5 mm wrench) on idler gear and manually move fold plate stop. Then move fold plate stop back to base position, all the way back, until deflector engages. Retighten Allen screws (see Adjustment of Fold Plates)
12	Gear motor for adjustment of paper stop jammed	Loosen mounting screws on gear motor and set fold plate stop manually by means of knurled screw
13	Fold plate stop jammed	Switch off main switch and then on again. Select correct fold plate depending on fold. Try to move fold plate stop out of base position via minus-key or by turning knurled screw

No:	Possible Cause:	Remedy:
14	Gap between fold plate and fold rollers not set correctly	Move fold plate to base position with the help of the scales
15	Fold roller gap too narrow	Increase fold roller gap by turning setting knob. Example: Turn scale at setting knob from 0.10 to 0.20
16	Delivery table plug not connected	Plug connection cable into adjacent fold unit
17	Voltage supply 30V in second fold unit defective	Replace fuse T4A
18	Different paper thickness	Re-adjust for paper thickness
19	Sheets from another folding job in stack	Remove sheet
20	Sheet gap too small	Increase sheet gap
21	Air flow too weak	Adjust air flow
22	Counting photodetector sometimes does not recognize sheets	Move photodetector to another position or check for proper function
23	Counting photodetector does not count	Check connections, clean photodetector
24	Drive belts in delivery section defective	Replace drive belts
25	Automatic setting of fold not yet completed	Wait until fold is set
26	Round belt in register table defective	Replace round belt
27	The safety switch for the feed table has been activated - the folder is not ready for operation	Lower the feed table to reset - the folder is again ready for operation