

Mathias Bäuerle GmbH · Gewerbehallestraße 7-11

D-78112 St.Georgen · Telefon (07724) 882-0 · Telefax (07724) 882-111

Internet: <http://www.mb-bauerle.de> · E-mail: center@mb-bauerle.de



Flat Pile Feeder FSA 52

Operator's Manual



CONTENTS

1.	Proper Handling of the Machine	5
2.	Safety Instructions	7
3.	Flat Pile Feeder	11

The title, copyright and all other proprietary rights in this document are vested in Mathias Bäuerle GmbH and no part of it may be reproduced in any form without the written permission of Mathias Bäuerle GmbH.

1. PROPER HANDLING OF THE MACHINE

The flat pile feeder FSA is built for feeding paper.
It is unsuitable for handling other materials such as foils, plastics and textiles.
The manufacturer / distributor is not responsible for damages resulting from such unsuitable applications. Responsibility lies alone with the user.

Reading the operator's manual and observing the conditions for inspection and maintenance are part of the proper handling of the machine.

Installation of the machine, i.e. assembling as well as electrical and pneumatic work should be carried out only by skilled personnel authorized by the manufacturer or his representatives.

Additional instructions are provided for this purpose.

Repairs and service should be carried out only by skilled personnel authorized by the manufacturer or his representatives.

The interval between inspections including safety-related functions depends on the machine usage.

For regular one-shift-operation, one inspection per year is recommended.

The machine needs a flat surface for installation.

The machine weight should be considered when choosing a location for the machine.

The levelling screws in the undercarriage of the machine can compensate for an uneven floor to a certain degree.

To ensure stability during operation the machine should be secured by means of the levelling screws.

The line voltage must correspond to the voltage on the serial plate.

No harmful emissions are produced.

Read the operator's manual before working with the machine!

We recommend to carry out all operations and settings in the sequence mentioned in this manual.



The terms "right" or "left" in the following text always refer to the direction of paper travel. Therefore the left side is the operator side.

2. SAFETY INSTRUCTIONS

2.1 Safety Instructions for Transport and Set-Up

The following instructions and warnings are applied to the packing to ensure appropriate and safe transport:

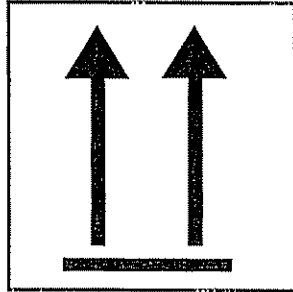

Top! Transport in upright position only!



Protect from humidity!

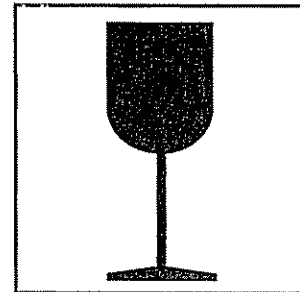

**Fragile!
Handle with care!**

These instructions and warnings must also be observed for transport within the users premises.

For transport to other premises resp. for return shipment the machines must be packed and provided with the same markings.

2.2 Fundamental Safety Instructions

Warnings and Symbols

The following symbols and designations are used in the manual to identify instructions of particular importance:



General instructions and special information how to use the machine most efficiently.



Instructions designed to prevent injury or extensive equipment damage

Basic Operation

The machine has been built in accordance with state-of-the art standards and the recognized safety rules.

Nevertheless, operators and third parties may get injured when working with the machine, or damage to the machine and to other material property may result

The machine must only be used in technically perfect condition in accordance with its designated use and the instructions set out in the operator's manual.

Any malfunctions, especially those affecting the safety of the machine, should therefore be rectified immediately.

Organizational Measures

The operator's manual must always be available near the machine.
In addition to reading the operator's manual, observe and instruct the user in all other generally applicable legal and other mandatory regulations relevant to accident prevention and environmental protection.
The operator's manual must be supplemented by instructions covering the duties involved in supervising and notifying special organizational features, such as job organization, working sequence or the personnel entrusted with the work.
Personnel entrusted with work on the machine must have read the operator's manual and in particular the chapter on safety before beginning the work.
Reading the instructions after work has begun is too late.
This applies especially to persons working occasionally on the machine, e.g. during setting up or maintenance.

Check, at least from time to time, whether the personnel is carrying out the work in compliance with the operator's manual and paying attention to risks and safety factors.
For reasons of safety, long hair must be tied back or otherwise secured, garments must be close-fitting and no jewellery - such as rings - may be worn.
Injury may result from being caught on moving parts.
Observe all safety instructions and warnings attached to the machine.
See to it that safety instructions and warnings attached to the machine are always complete and perfectly legible.
In the event of safety-related modifications or changes in the performance of the machine during operation, stop the machine immediately and report the malfunction to the competent person.

Never make any modifications, additions or conversions which might affect safety without the manufacturer's approval. Adhere to prescribed intervals or those specified in the operator's manual for routine checks and inspections.

Selection of Personnel, Basic Responsibilities

Employ only trained or instructed staff and set out clearly the individual responsibilities of the personnel for operation, set-up, maintenance and repair.
Work on the electrical system and equipment of the machine must be carried out only by a skilled electrician or by instructed persons under the supervision and guidance of a skilled electrician and in accordance with electrical engineering rules and regulations.

Standard Operation

Avoid any operational mode that might be detrimental to safety.
Take the necessary precautions to ensure that the machine is used only in a safe and reliable state. Operate the machine only if all protective and safety-oriented devices, such as removable safety devices, emergency stops, sound-proofing elements, are in place and fully functional.
In the event of malfunctions stop the machine immediately and prevent further use.
Have any defects rectified immediately.
Before starting up or setting the machine in motion, make sure that nobody is in danger.

Special Work, Maintenance, Repair

Observe the adjusting, maintenance and inspection activities and intervals set out in the operator's manual, including information on the replacement of parts and equipment.
Pull the power plug for maintenance and repair work or before opening the control box.
If the machine is completely shut down for maintenance and repair work, it must be secured against inadvertent starting by attaching a warning sign to the main switch.
Always tighten any screw connections that have been loosened during maintenance and repair.

Special Dangers

The electric equipment of machines is to be inspected and checked at regular intervals. Defects such as loose connections or scorched cables must be rectified immediately.

Product-Specific Safety Instructions



Exercise caution in the vicinity of rotating shafts and rollers!
Hair, loose garments and jewellery may get caught!
SERIOUS INJURY MAY RESULT!

2.3 Cleaning and Maintenance

Regular and proper cleaning contributes to a long life of the machine and a consistent quality. Therefore it is important to clean the machine in regular intervals and above all to remove paper dust.

The intervals between maintenance jobs depend on the workload.
It is recommended to clean the machine once a week.



Before cleaning the machine always pull the power plug!

Use only the special cleaning fluid from MB for cleaning the fold rollers.

Do not use any solvents such as Aceton or Toluol. They would damage the non-metal parts of the rollers!

Remove paper- or print powder dust from all fixed and movable parts of the machine.

Clean the photodetectors with a brush.

Use compressed air to clean the fold plates when paper with a high degree of powder has been folded. Carefully remove deposits in the control box with a vacuum cleaner.

Clean the air filter of the compressor and the pump using brushes or air.

The maintenance-free flat belt drive needs no lubrication of any kind.

3. FLAT PILE FEEDER FSA

Principle of Operation The flat pile feeder FSA with rear edge separator is suitable for separating different kinds of paper, uncoated as well as coated, freshly printed or thin paper

Sheet separation is done by vacuum and air from the top of the paper stack.
 Air blowers separate the top sheets at the rear edge of the stack.
 Sheet separators lift the uppermost sheet by approx. 2 cm.
 This opens the rear air nozzles and an uninterrupted stream of air is blown under the separated sheet.
 The suction drum at the front edge of the stack grips the sheet and leads it onto the register table.

Description

Components and operating elements of the flat pile feeder FSA:

- 1 Pile table
- 2 Stacking stops
- 3 Carrier arm for rear edge separator
- 4 Rear edge separator
- 5 Operator panel
- 6 Valves for regulating the air flow
- 7 Sheet separator height adjustment
- 8 Knurled knob for rear edge separator
- 9 Knurled knob for stripper springs
- 10 Rear separator nozzles
- 11 Front separator nozzles
- 12 Hold-down rods
- 13 2 sucker cups
- 14 Suction drum with suction segment
- 15 Lever for adjustment of suction segment
- 16 Rear edge separator lock lever

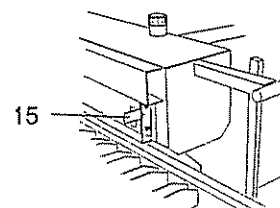
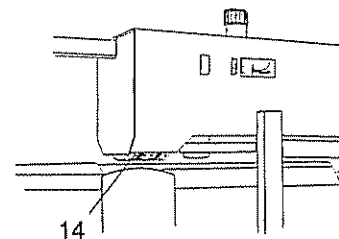
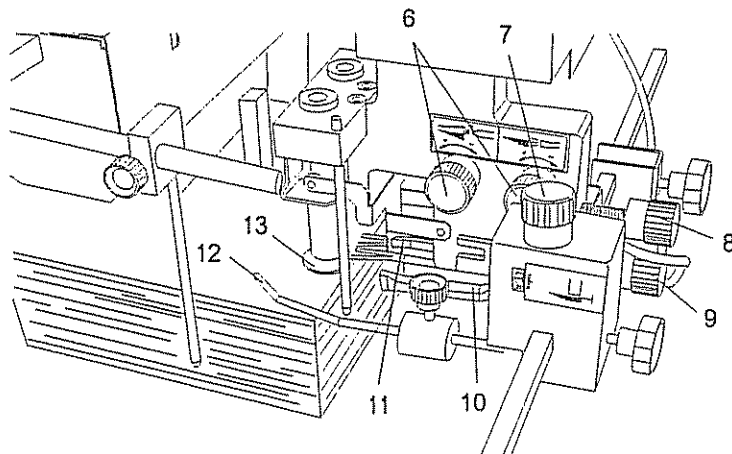
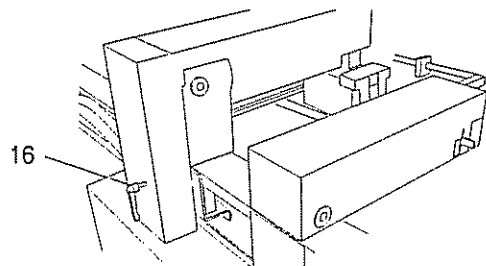
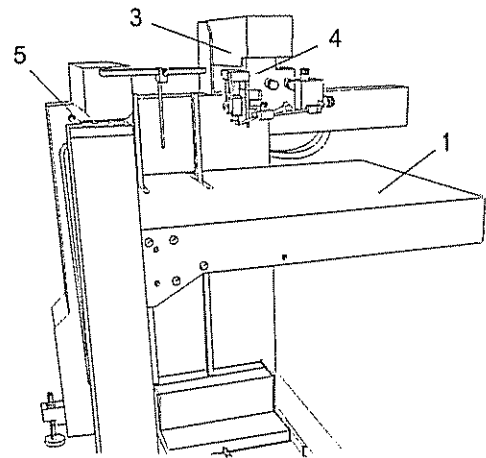

Setting the Format

- Tilt up the front stop (1).
- Push down the rear stop rod (2) and slide it to half the sheet width with the help of the scale (3).



The second rear stop (4) can be pulled out. This is necessary, if, for instance, the rear edge separator is in this position when feeding smaller paper sizes.

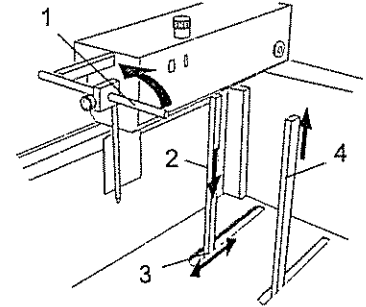

Loading the Pile Table

- Turn on the main switch at the folder.
- Lower the pile table.

The operator panel of the flat pile feeder has three push-buttons for lowering and raising the pile table.

Button (5) Pile table up:
The pile table moves up automatically to the correct position.

Button (6) Pile table down:
The pile table moves down, but only as long as the push-button is pressed.

Button (7) Auto mode:
The feeder is designed in such a way that the pile table moves down automatically for reloading. This ensures that the loading height is always in an ergonomically favorable position. The distance that the pile table moves down corresponds to the height of the paper stack that is being replenished. The height adjustment is controlled by a photodetector (8). The photodetector can be adjusted by loosening a knob (9), thus making it possible to adapt the stack height to suit the operator.

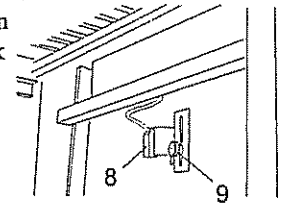
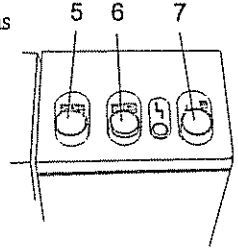

- Tilt up the rear edge separator (10).
- Load paper on the pile table.



Use the automatic stacking mechanism. Push button (7) after each reloading process. This will lower the table automatically.

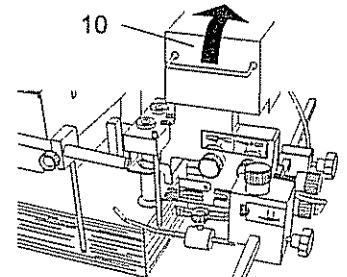

Moving the Paper Stack to Work Position

When the pile table is loaded, the paper stack must be brought to the work position.

- Push button (1).
The stack moves automatically to the correct position, controlled by the stack sensor switch (2).



The stack height switch is a capacitive sensor that reacts to the density of the paper stack. For this reason the gap between stack and suction drum can vary when the paper stack has reached the work position depending on the type of paper used.

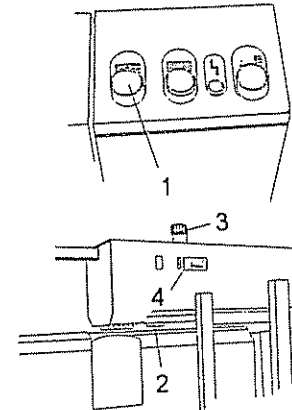

The gap between stack and suction drum should be 8 mm

- Set the gap to 8 mm by turning the setting screw (3).
A scale (4) facilitates this setting.
- Lower the front stop (5) and slide it against the paper stack.



This tiltable stop can also be replaced by a stop rod (6).
The stop rod is attached to the pile table with a lock screw (7).
The tiltable stop (5) must then be moved up so that it does not interfere with the stop rod.

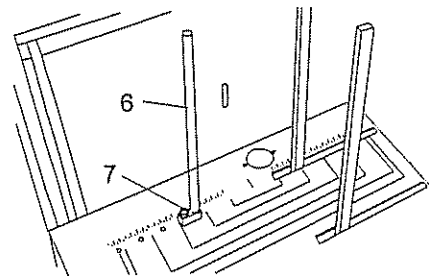
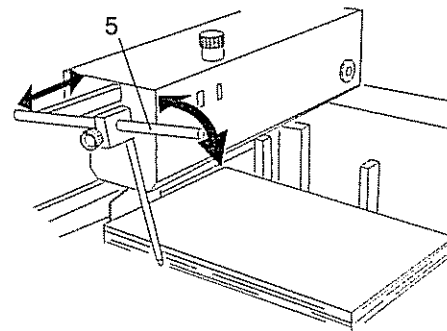

Air and Vacuum

Turn on the pump at the operator panel before setting air and vacuum.
The correct setting for air and vacuum can only be determined by running a few sample sheets after all adjustments have been completed.

Exchanging the Suction Drum

The suction drum (1) is equipped with two PUR-rings for reliable sheet detachment. If marks occur on sensitive or freshly printed paper, a different suction drum (accessory) can be used.

This suction drum has a PUR-coating over the entire surface and consequently a higher coefficient of friction.

- Pull off the cover (2).
- Loosen the screw (3) and remove the suction drum.
- Install the PUR suction drum.
- Tighten the screw (3).
- Replace the cover (2).

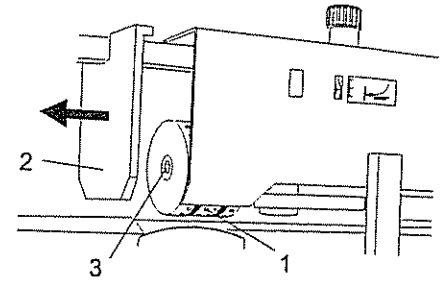

Adjusting the Suction Drum

The suction drum (4) separates the leading edge of the sheets from the stack. For this purpose there is a suction segment inside the suction drum.

The suction angle can be changed by adjusting the lever (5) to adapt suction point and suction area to different types of paper.

A scale (6) facilitates the adjustment.

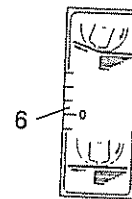
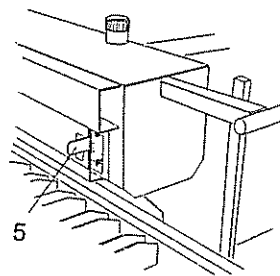
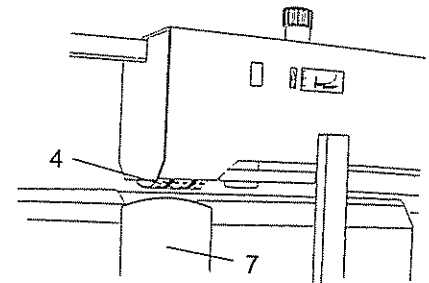

In most cases an adjustment is only necessary for light paper stock resp. paper with a downward curl.



Fine adjustment is only possible with the machine running.



In connection with the adjustment of the suction segment, the height of the separator plate (7) can also be varied.

Setting the Rear Edge Separator

- Lower the rear edge separator (1).
- Loosen the lock lever (2).

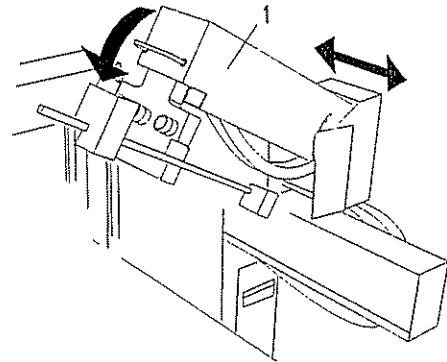
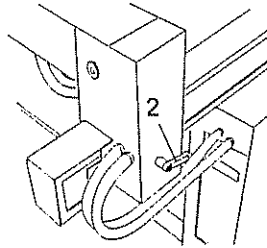

- Displace the rear edge separator in such a way that the stop rods (3) touch the rear edge of the paper stack.



The edges of the sucker cups (4) should be placed approx 3-4 mm from the rear edge of the paper stack.



For light paper stock it is recommended to place the suckers even closer to the rear edge of the stack. This is achieved by moving the stop rods (3) to the next set of holes (5).

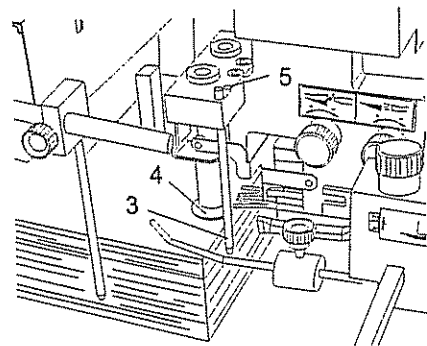

- Tighten the separating head by turning the lock lever (2) clockwise.

- Slide the left and right hold-down rods (6) towards the outer edge of the paper stack (approx 1 cm inside the edge).

- Adjust the pressure of the hold-down rods:
 - Heavy paper grades: Slide the weight (7) up.
 - Light paper grades: Slide the weight (7) down.

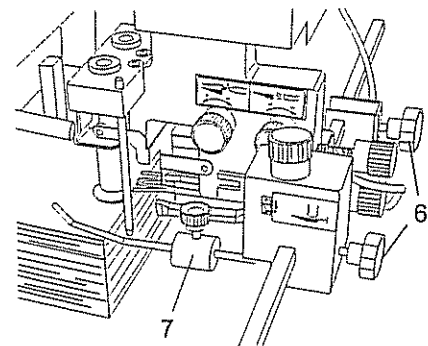

- Check whether the automatic height setting mechanism is switched on.



The automatic height setting mechanism can be switched on and off by pushing button (8). The illuminated button shows that it is active.

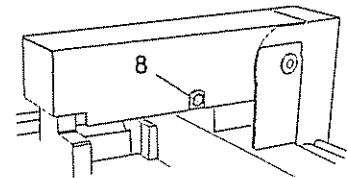

For smaller paper sizes or flat sheets the automatic height adjustment is often not needed and can therefore be switched off.

- Adjust the automatic height setting as follows:

The left hold-down bracket (1) also serves as a height sensor, controlling the height adjustment of the rear edge separator

As a result, the gap between the suckers and paper stack remains always the same although sheets are pulled off continuously.

The basic position can be changed by means of a knob (2).

A scale (3) facilitates the adjustment.

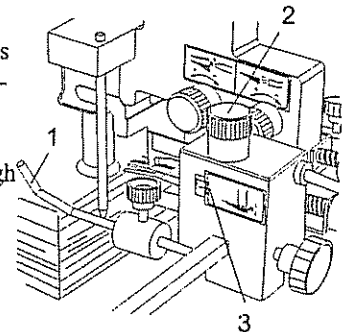

Increasing the gap:

Move indicator to the plus-range „+“

Reducing the gap:

Move indicator to the minus-range „-“

Basic setting:

Sucker cups should be 1-2 mm above the paper stack (with air turned off)

Adjusting the Stripper Springs

The stripper springs (4) should reach about 2 mm into the stack to prevent double sheets. The position of the springs can be adjusted by means of a thumb screw (5).

- Turn the thumb screw counter-clockwise:
Springs move away from the stack.
- Turn the thumb screw clockwise:
Springs move into the stack.

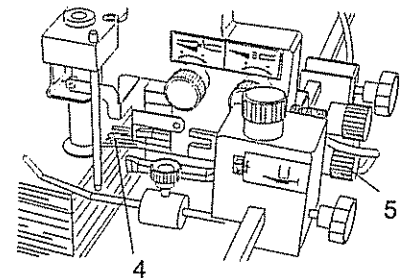

If double sheets occur, the stripper fingers must be adjusted in such a way that they reach further into the stack.

Making the Sucker Cups Inoperative



For short formats it is often advantageous to work without rear edge separators. In this case the sucker cups can be made inoperative.

- Move the sucker cups to the top position (6).
- Push the lock lever (7) backwards. This will lock the sucker cups in the top position.
- Switch off the automatic height adjustment mechanism.

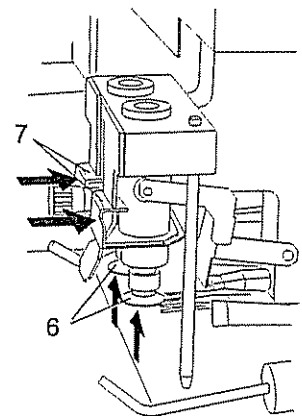

Now the air continuously separates the sheets from the rear edge.

Air

The air separates the rear edge of the paper stack by means of two rear separator nozzles (1). The volume of the air can be adjusted by means of a valve (2). The effect of the air can be influenced by changing the angle of the rear separator nozzles. They can be pointed up- or downwards by turning a thumb screw (3).

- Air directed upwards:
Turn the screw counter-clockwise.
Too high: Double sheets may occur.
- Air directed downwards:
Turn the screw clockwise
Too low: Sheets on top are not fanned properly.

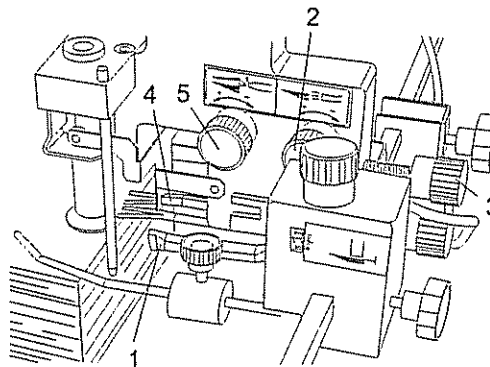

Air volume and angle are set correctly when the top 10-15 sheets separate easily.



Use as little air as possible for proper function.

Another separator nozzle (4) is positioned between the rear separator nozzles. It creates an air cushion under the separated sheet so that it attaches itself to the suction drum. The air volume can be adjusted by means of the valve (5).



Most setting elements are equipped with scales. For repetitive feeding jobs it is recommended to mark the settings at the scales. The machine can thus be set-up more quickly. Please note that the same result can only be reached if all conditions are the same.

To support the air cushion, front blowers (6) can be used. They blow air under the leading edge of the sheets so that the sheets cling more easily to the suction drum.

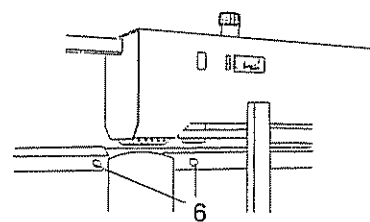

The air volume can be controlled by means of a valve (7), which can be closed completely by turning it clockwise.

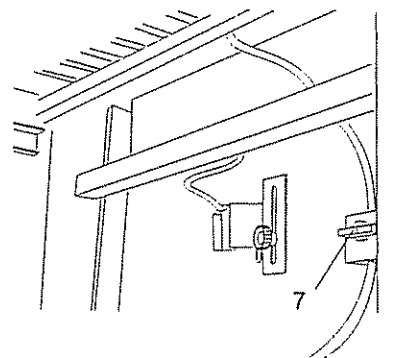

Additional Blower

An additional single blower (1) (optional) stabilizes the air cushion near the leading edge of the floating sheet. This is especially useful for long and narrow sheets.

The single blower (1) is positioned next to the front stop (2), while the stop plate (3) which comes with each single blower is pushed onto the rear paper stops.

When the single blower is used, the front blowers must be made inoperative. For this purpose detach the hose (4) for the front blowers from the valve (5) and connect the air hose (6) of the individual blower in its place.

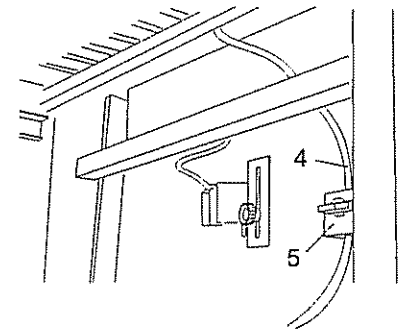
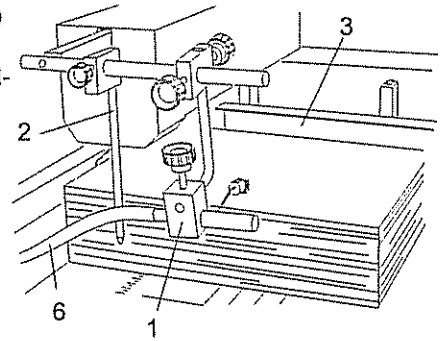

Side Blowers

The feeder can also be equipped with side blowers in the place of the rear edge separator (see separate mounting instructions).

By supplying air to the side and rear edge of the stack, the topmost sheets are detached so that separation through the suction drum is possible.

Contrary to operation with the rear edge separator, the topmost sheet is not lifted.

The air nozzles (7) are attached to cross-bars at the side (8) and the rear (9) of the paper stack. For replenishing paper, the two cross-bars can be raised to provide access to the pile table.

After the replenishing process the bars are returned to the working position.

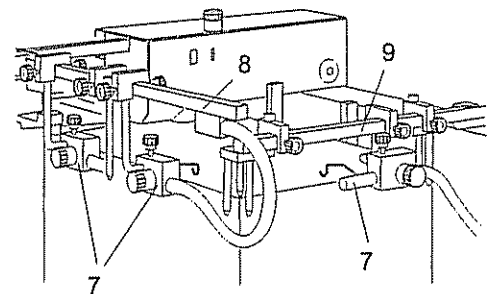

Format setting:

- Move the rear cross-bar (1) (secured with a clamp lever) in such a way that the sheet stop rods (2) are placed against the left- and right-hand side edge as well as against the rear edge of the stack.

The weight rods (3) on the left- and right-hand side must touch the corners of the stack.

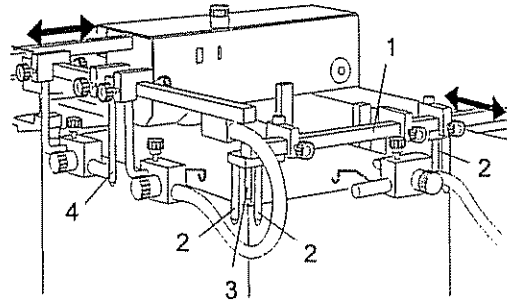

- Move the lateral cross-bar until the side stop (4) touches the stack
- Adjust the air nozzles in such a way that they are approx. 1 to 2 cm away from the side - resp rear edge.
- Adjust the angle of the air flow by turning the air nozzles so that about 10 sheets are separated.

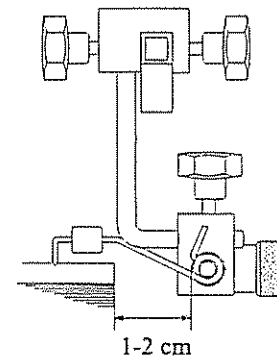

The amount of air can be fine-adjusted by means of valves (5).

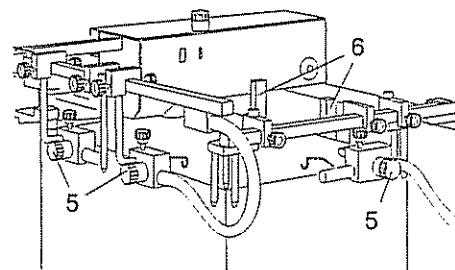

The air cushion must not be so strong that the sheets under the suction drum are compressed

Place the stop plate on the rear stops (6) so that an air cushion is created.

Side Stop, Right-Hand Side

A special side stop at the right-hand side is part of the "side blower" kit. This stop should be used when the paper tends to drift sideways.

The side stop is attached to the arm of the suction wheel and can be moved sideways so that it can be set to the format width.

