

**SINKING STACKER**

**TC 1200**

**OPERATING MANUAL**

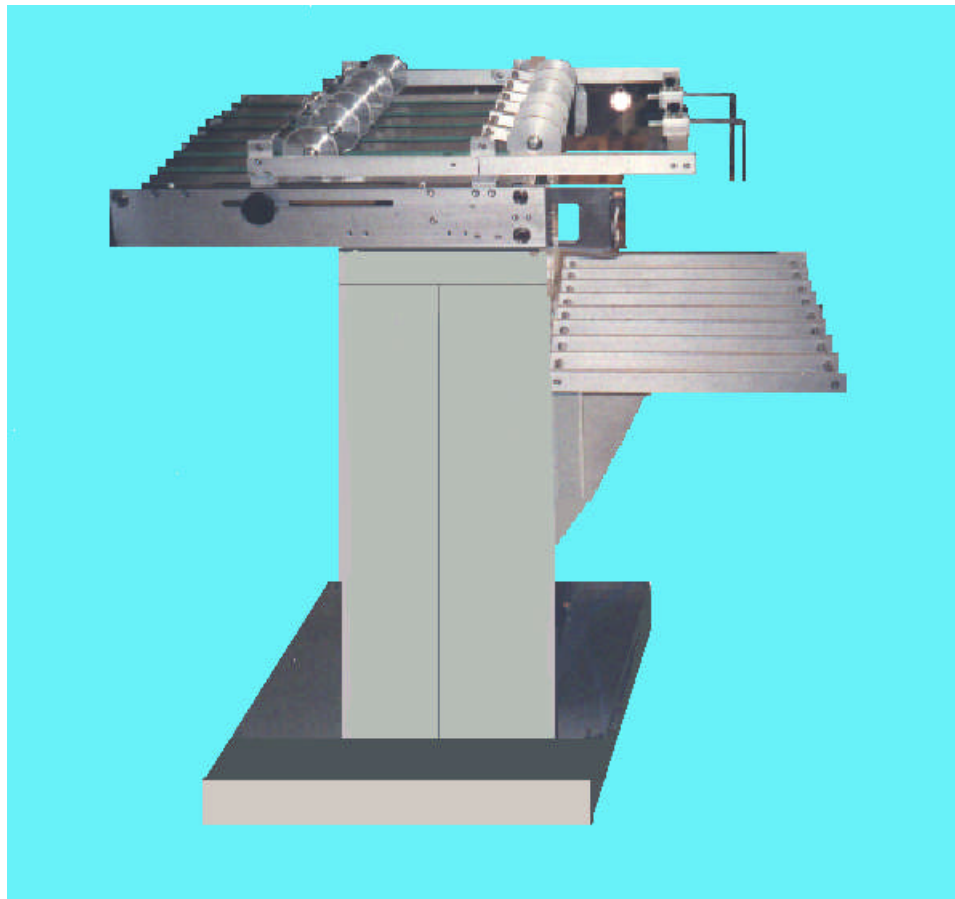

**SINKING STACKER**

**1. INSTALLATION**

- After removing the side cover of the cutter, connect the cable of the stacker to the connector placed on the cutter side, fix the cable and connect the ground wire.
- Set the cutter parameter “**STACKER CONNECTED**” at “**1**” as indicated in the Cutter User Manual, section “Cutter Parameters”, point 10.

***SINKING STACKER***

**2. ADJUSTMENTS**

- Adjust the cutter height in order to have the output paper level approx. 40 mm higher than the stacker output paper plane.
- Adjust the position of the first line of wheels, that receive the paper, at the same measure of the form cut. To do it, turn the side handles out and move them following the references of the two side graduated (inches) lines.
- Adjust the paper limits, placed on the descending stacker plane, at the same measure, using, as reference, one cut paper module.

**SINKING STACKER**

**3. OPERATING INSTRUCTION**

- To start the job, switch ON the cutter, load the paper and verify that the stacker paper collecting plane is in the position “high”; if it isn’t, press the “**F1**” key.
- Press the key “**START**” of the keyboard to start the job.
- The cutter automatically stops when the stacker is full.  
To start again, follow this procedure:
  - Empty the paper plane.
  - Press **F1** to set the stacker paper plane in the position “high”.
  - Press **RESET** before starting the new job.

**SINKING STACKER**

**TECHNICAL SPECIFICATION**

Paper Specification

- Form width: 480 mm max
- Form length: Min 4", Max 16"

Stacker Characteristics

- Stacker Capacity: up to 2000 sheets (250 mm height)
- Paper output plane: 960 mm

Size and weight

- Width: 800 mm
- Length: 920 mm
- Height: 1030 mm
- Weight: 80 kg

Power requirement

- 230V/110V – 50/60 Hz